

The original documents are located in Box 9, folder “Emergency Broadcast System (3)” of the Ron Nessen Papers at the Gerald R. Ford Presidential Library.

Copyright Notice

The copyright law of the United States (Title 17, United States Code) governs the making of photocopies or other reproductions of copyrighted material. Ron Nessen donated to the United States of America his copyrights in all of his unpublished writings in National Archives collections. Works prepared by U.S. Government employees as part of their official duties are in the public domain. The copyrights to materials written by other individuals or organizations are presumed to remain with them. If you think any of the information displayed in the PDF is subject to a valid copyright claim, please contact the Gerald R. Ford Presidential Library.

DECEMBER 1975

EMERGENCY BROADCAST SYSTEM PROCEDURES

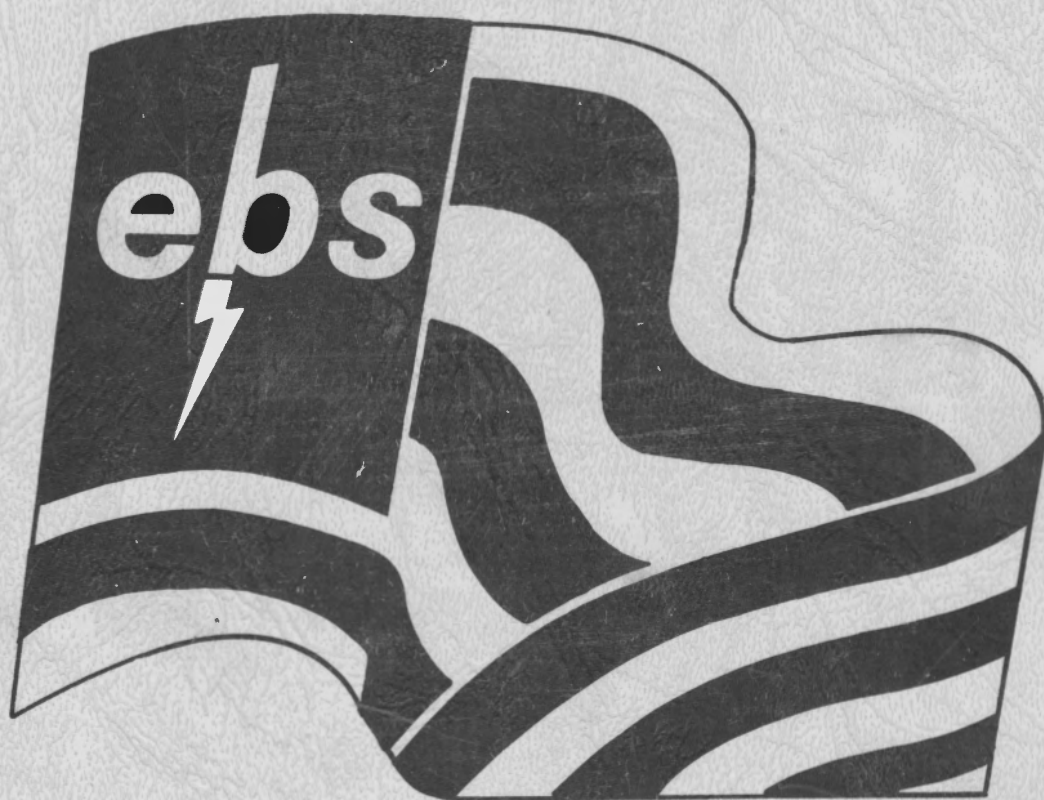

U.S. ARMY INTERAGENCY COMMUNICATIONS AGENCY

FOR OFFICIAL USE ONLY

WARNING NOTICE

THE EMERGENCY BROADCAST SYSTEM IS A COMBINED EFFORT OF THE BROADCAST INDUSTRY, PRESS WIRE SERVICES, TELEPHONE COMPANY, AND GOVERNMENT ACTIVITIES WHICH CAN QUICKLY AFFECT THE ENTIRE UNITED STATES. IRREGULARITIES IN PROCEDURES, EQUIPMENT, AND CIRCUITRY WHICH REACH INDUSTRY CAN CREATE PROBLEMS OF EPIC PROPORTIONS.

ANY EMPLOYEE NOTING ANY IRREGULARITIES, INCLUDED IN BUT NOT LIMITED TO THE ABOVE, WITH RESPECT TO USAICA'S RESPONSIBILITIES IN THE EBS WILL IMMEDIATELY NOTIFY THE USAICA SYSTEMS CONTROLLER.

HEADQUARTERS
U.S. ARMY INTERAGENCY COMMUNICATIONS AGENCY
POST OFFICE BOX 886
WINCHESTER, VIRGINIA 22601

CCI-OD

11 February 1976

SUBJECT: Change 1, USAICA EBS Procedures

SEE DISTRIBUTION

1. Reference USAICA Emergency Broadcast System Procedures, December 1975.

2. The following pen and ink changes constitute Change 1 to reference:

a. Basic Procedures:

(1) Page vi - ADCOM definition - Correct spelling of Colorado.

(2) Page 19 - para 16, 1st line - Correct spelling of Procedures.

(3) Page 2, Annex F:

(a) Para 3d, 1st line - Change COMMCEN to U CMC.

(b) Para 3f, 1st line - Change to read, "U SC notifies WTO and U CMC that . . ."

(4) Page 2, Annex G - WHCA - Change commercial code (91) to (8-19).

(5) Page 1, Appendix 4 to Annex H - Add "AT&T PGO C HARRISBURG PA (MAIL)" as an info addressee.

(6) Page 1, Annex J - Station 500 - Change alternate AUTOVON number to 380-5266.

(7) Annex K:

(a) Page 1 - OTP - Change contact's rank to COL.

(b) Page 3 - Harrisburg PGO C - Change 2nd line of address to: Mr. W. P. Over.

CCI-OD
SUBJECT: Change 1, USAICA EBS Procedures

11 February 1976

b. Supplement:

(1) Page 12 - Add the following dialogue to para 10:
"This is an actual NIAC Order Change. Prepare to copy."

(2) Page 51 - Explanation of abbreviations - Change
U CSC to U CMC.

3. This letter may be destroyed after indicating on page 11
that this change has been made.

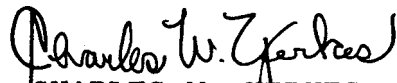
CHARLES W. YERKES
Colonel, Signal Corps
Commanding

DISTRIBUTION:

OTP
ADCOM
FPA (3)
FPA/WVOO
WCD/DCA (2)
WHCA
7th Sig Comd
USACC DCPA Spt Agcy
AT&T WASH-1
AT&T WASH-4
AT&T Harrisburg PGO
USAICA
Cdr
Tech Dir (2)
Comm Ops Div (8)
COMSEC Div
Log Div (2)
Plans Ofc

HEADQUARTERS
U.S. ARMY INTERAGENCY COMMUNICATIONS AGENCY
POST OFFICE BOX 886
WINCHESTER, VIRGINIA 22601

CCI-OD

19 August 1976

SUBJECT: Change 2, USAICA EBS Procedures, December 1975

See Distribution

1. Remove the following pages and replace with attached:
Pages 1 and 2 of Appendix 1 to Annex H; Appendixes 2, 3, and 4 to Annex H; and Annexes I, J, and K.
2. The residue may be destroyed after indicating on page ii that this change has been made.

10 Incl
as

Richard G. Karl
for CHARLES W. YERKES *cc Sjic*
Colonel, Signal Corps *DCB*
Commanding

DISTRIBUTION:

OTP
ADCOM
FPA (3)
FPA/WVOO
WCD/DCA (2)
WHCA
7th Sig Comd
USACC DCPA Spt Agcy
AT&T WASH-1
AT&T WASH-4
AT&T Harrisburg PGO
USAICA
Cdr
Tech Dir (2)
Comm Ops Div (8)
COMSEC Div
Log Div (2)
Plans Ofc

JOINT MESSAGEFORM

SECURITY CLASSIFICATION

UNCLAS

PAGE	DRAFTER OR RELEASE TIME	PRECEDENCE		LME	CLASS	CIC	FOR MESSAGE CENTER/COMMUNICATIONS CENTER ONLY			
		ACT	INFO				DATE - TIME	MONTH	YR	
1 OF 6		ROUTINE								

BOOK

MESSAGE HANDLING INSTRUCTIONS

To be transmitted within 2 working days after Closed Circuit Test

FM CDRUSAICA WINCHESTER VA //CCI-TD-SC//

TO OTP WASH DC

INFO WHCA WASH DC

FCC WASH DC

ADCOM COC CHEYENNE MTN COMPLEX CO //DCMS//

DCA WASH DC //544//

UNCLAS

CITE ICA _____.

SUBJ: EBS CLOSED CIRCUIT TEST

SECTION I - ACTIVATION

1. ON (date), THE WTO DIRECTED THE USAICA SYSTEMS CONTROLLER TO ORIGINATE AN EBS CLOSED CIRCUIT TEST. SEQUENCE OF EVENTS FOLLOWS:

- A. (Time), WASHINGTON, DC, TIME, CALL RECEIVED FROM WTO.
- B. AUTHENTICATOR CHALLENGE _____; AUTHENTICATOR RESPONSE _____.
- C. TEST TIME GIVEN BY WTO WAS _____.
- D. NIAC ORDER NO _____.
- E. (Time) - TEST PROGRAM SCHEDULED TO BEGIN.

DISTR:

USAICA MAIL DESK; PLANS OFC, COMM OPS DIV {4}

SCB: AT&T WASH 4

DRAFTER TYPED NAMED, TITLE, OFFICE SYMBOL AND PHONE

SPECIAL INSTRUCTIONS

RELEASE	TYPED NAME, TITLE, OFFICE SYMBOL AND PHONE	FCC VIA DEFCORD DCA AND OTP VIA TELECOPIER
	SIGNATURE	
	SECURITY CLASSIFICATION	

C
L
O
S
E
D

C
I
R
C
U
I
T

T
E
S
T

R
E
P
O
R
T

F
O
R
M
A
T

6
5
4
3
2
1
0

JOINT MESSAGEFORM

SECURITY CLASSIFICATION

UNCLAS

PAGE	DRAFTER OR RELEASER TIME	PRECEDENCE		LME	CLASS	CIC	FOR MESSAGE CENTER/COMMUNICATIONS CENTER ONLY			
		ACT	INFO				DATE - TIME	MONTH	YR	
2 OF 6										

BOOK

MESSAGE HANDLING INSTRUCTIONS

F. (Time) - TRANSMISSION OF TEST ACTIVATION MESSAGE STARTED OVER 500 NET. MESSAGE AUTHENTICATOR WAS _____.

G. (Time) - VOICE CONFIRMATION OVER 300 NET OF RECEIPT OF TEST ACTIVATION MESSAGE BY AP, UPI, AND ADCOM.

H. (Time) - TRANSMISSION OF TEST ACTIVATION MESSAGE OVER 500 NET COMPLETED.

I. (Time) - THREE POLLING CYCLES COMPLETED. ACKNOWLEDGEMENT NOT RECEIVED FROM (number) STATIONS.

J. (Time) - DELINQUENT STATIONS REACTIVATED AND TELEPHONING COMMENCED. TELEPHONE CALLS NECESSARY TO STATIONS _____.

K. (Time) - ALL ACKNOWLEDGEMENTS COMPLETE.

L. (Time) - NOTIFIED WTO ALL ACTIONS COMPLETED.

M. (Time) - NOTIFIED NBWC OF EBS TEST ACTIVATION.

2. ELAPSED TIMES FROM INITIATION BY WHCA:

A. _____ MINUTES TO START OF 500 NET TRANSMISSION.

B. _____ MINUTES TO RECEIPT OF ALL 500 NET ACKNOWLEDGEMENTS.

3. PROBLEMS: [Give any problems such as complete net failure, need to transfer action to ADCOM, etc., and corrective action taken.

DISTR:

DRAFTER TYPED NAMED, TITLE, OFFICE SYMBOL AND PHONE

SPECIAL INSTRUCTIONS

**R
T
Y
P
E
D
N
A
M
E,
T
I
T
L
E,
O
F
F
I
C
E
S
Y
M
B
O
L
A
N
D
P
H
O
N
E**

**S
I
G
N
A
T
U
R
E**

C2

SECURITY CLASSIFICATION

0
1
2
3
4
5
6

JOINT MESSAGEFORM

SECURITY CLASSIFICATION

UNCLAS

PAGE	DRAFTER OR RELEASER TIME	PRECEDENCE		LMF	CLASS	CIC	FOR MESSAGE CENTER/COMMUNICATIONS CENTER ONLY			
		ACT	INFO				DATE - TIME	MONTH	YR	
1 OF 3		ROUTINE								

BOOK MESSAGE HANDLING INSTRUCTIONS
To be completed within three working days after test.

FM CDRUSAICA WINCHESTER VA //CCI-TD-SC//
 TO OTP WASH DC
 INFO WHCA WASH DC
 FCC WASH DC
 ADCOM COC CHEYENNE MTN COMPLEX CO //DCMS//
 DCA WASH DC //544//
 UNCLAS
 CITE ICA _____.
 SUBJ: ICE HOUSE TEST ON (date)
 1. SEQUENCE OF SUBJECT TEST FOLLOWS:
 A. (Time), WASHINGTON, DC, TIME, CALL RECEIVED FROM WTO.
 B. AUTHENTICATOR CHALLENGE _____; AUTHENTICATOR RESPONSE
 _____.
 C. TEST TIME GIVEN BY WTO WAS _____.
 D. (Time) - TRANSMISSION OF TEST ACTIVATION MESSAGE STARTED OVER
 500 NET.
 E. (Time) - VOICE CONFIRMATION OVER 300 NET OF RECEIPT OF TEST
 MESSAGE BY AP, UPI, AND ADCOM.

DISTR:
 USAICA MAIL DESK: PLANS OFC, COMM OPS DIV {4}
 SCB: AT&T WASH-4

RELEASER	DRAFTER TYPED NAMED, TITLE, OFFICE SYMBOL AND PHONE	SPECIAL INSTRUCTIONS DCA AND OTP VIA TELECOPIER
	TYPED NAME, TITLE, OFFICE SYMBOL AND PHONE	
	SIGNATURE	C2, Appendix 2 to Annex H
		SECURITY CLASSIFICATION UNCLAS

ICE HOUSE TEST REPORT FORMAT

6543210

0

JOINT MESSAGEFORM

SECURITY CLASSIFICATION
UNCLAS

PAGE	DRAFTER OR RELEASER TIME		PRECEDENCE		LMF	CLASS	CIC	FOR MESSAGE CENTER/COMMUNICATIONS CENTER ONLY		
	ACT	INFO	DATE - TIME	MONTH				YR		
2 OF 2										

BOOK MESSAGE HANDLING INSTRUCTIONS

F. (Time) - TRANSMISSION OF TEST MESSAGE OVER 500 NET COMPLETED.

G. (Time) - THREE POLLING CYCLES COMPLETED. ACKNOWLEDGEMENT NOT RECEIVED FROM (number) STATIONS.

H. (Time) - ALL ACKNOWLEDGEMENTS COMPLETED BY REACTIVATION OR TELEPHONING.

I. (Time) - NOTIFIED WFO ALL ACTIONS COMPLETED.

J. (Time) - NOTIFIED NWC OF TEST.

2. ELAPSED TIMES FROM INITIATION BY WHCA:

A. _____ MINUTES TO START OF 500 NET TRANSMISSION.

B. _____ MINUTES TO COMPLETION OF NET TRANSMISSION.

C. _____ MINUTES TO RECEIPT OF ALL 500 NET ACKNOWLEDGEMENTS.

3. PROBLEMS: [Give any problems such as complete net failure, need to transfer action to ADCOM, etc., and corrective action taken. On 300 Net, state if equipment problem or customer error; if equipment problem, include corrective action taken. On 500 Net, list: (1) Any problems caused by ASR operation and corrective action taken, (2) Stations which did not acknowledge during initial three polling cycles, (3) Stations which responded to the "Please Acknowledge"

DISTR:

DRAFTER TYPED NAMED, TITLE, OFFICE SYMBOL AND PHONE		SPECIAL INSTRUCTIONS
RELEASER	TYPED NAME, TITLE, OFFICE SYMBOL AND PHONE	
	SIGNATURE	
SECURITY CLASSIFICATION UNCLAS		C2

6
5
4
3
2
1
0

JOINT MESSAGEFORM

SECURITY CLASSIFICATION

UNCLAS

PAGE	DRAFTER OR RELEASER TIME	PRECEDENCE		LMF	CLASS	CIC	FOR MESSAGE CENTER/COMMUNICATIONS CENTER ONLY			
		ACT	INFO				DATE - TIME	MONTH	YR	
3 OF 3										

BOOK MESSAGE HANDLING INSTRUCTIONS

message before being called, (4) Stations which did not respond to "Please Acknowledge" tape and were telephoned, (5) Whether good copy of message was received, (6) Whether visual lamp lit, and (7) If after key operated, whether answer-back was received at ASR. If (5), (6), and (7) are affirmative, identify as subscriber error. If equipment problems existed, so state and include corrective action taken.]

4. REMARKS: (Include in this paragraph such items as substantive problems which have occurred since the last test; test results of NIAC 1/2 circuitry; and any recommendations which do not logically fall in other paragraphs.) h

6
5
4
3
2
1
0

DISTR:



DRAFTER TYPED NAMED, TITLE, OFFICE SYMBOL AND PHONE		SPECIAL INSTRUCTIONS
R E L E A S E R	TYPED NAME, TITLE, OFFICE SYMBOL AND PHONE	
	SIGNATURE	
SECURITY CLASSIFICATION UNCLAS		C2

JOINT MESSAGEFORM						SECURITY CLASSIFICATION UNCLAS					
PAGE	DRAFTER OR RELEASER TIME	PRECEDENCE		LMF	CLASS	CIC	FOR MESSAGE CENTER/COMMUNICATIONS CENTER ONLY				
		ACT	INFO				DATE - TIME		MONTH	YR	
1 OF 1		ROUTINE									
BOOK		MESSAGE HANDLING INSTRUCTIONS To be completed monthly within three working days after last test.									
<p>FM CDRUSAICA WINCHESTER VA //CCI-OD-AV//</p> <p>TO DCA //CODE 544//</p> <p>CDR7TH SIG COMD FT RITCHIE MD //CCN-P0-0P//</p> <p>INFO AIG 870</p> <p>UNCLAS</p> <p>CITE. ICA _____.</p> <p>SUBJ: MODIFIED TESTING OF THE EBS. (Month and Year)</p> <p>REF: A. DCA MSG 512-4/1404 10 JAN 67.</p> <p>B. USAICA MSG SS88454 20 MAR 67.</p> <p>(Only list those tests which were not successful or were cancelled and the reasons therefore.) h</p>											
<p>DISTR:</p> <p>USAICA MAIL DESK: COD (2), LOG DIV, PLANS OFC, AND SCB</p>											
DRAFTER TYPED NAMED, TITLE, OFFICE SYMBOL AND PHONE						SPECIAL INSTRUCTIONS					
TYPED NAME, TITLE, OFFICE SYMBOL AND PHONE						DCA VIA TELECOPIER					
SIGNATURE						C2, Appendix 3 to Annex H					
						SECURITY CLASSIFICATION UNCLAS					

MODIFIED TEST REPORT FORMAT

6
5
4
3
2
1
0

0

JOINT MESSAGEFORM

SECURITY CLASSIFICATION
UNCLAS

PAGE	DRAFTER OR RELEASER TIME	PRECEDENCE		LMF	CLASS	GIC	FOR MESSAGE CENTER/COMMUNICATIONS CENTER ONLY		
		ACT	INFO				DATE - TIME	MONTH	YR
1 OF 2		ROUTINE							

BOOK MESSAGE HANDLING INSTRUCTIONS
To be completed within three working days after test.

FM CDRUSAICA WINCHESTER VA //CCI-OD-AV//
 TO OTP WASH DC
 INFO WHCA WASH DC
 DCA WASH DC //544//
 AT&T PGO C HARRISBURG PA {MAIL}
 UNCLAS
 CITE ICA _____.
 SUBJ: EBS MYSTIC TARGET TEST BY (Radio/Telephone)
 1. ON (date) THE WTO DIRECTED THE USAICA SYSTEMS CONTROLLER TO
 ORIGINATE AN EBS MYSTIC TARGET TEST. THE SEQUENCE OF EVENTS FOLLOWS:
 A. (Time), WASHINGTON, DC, TIME, CALL RECEIVED FROM (name), WTO,
 OVER (telephone number or radio frequency).
 B. AUTHENTICATOR CHALLENGE _____; AUTHENTICATOR RESPONSE
 _____.
 C. NIAC ORDER NO. _____ SIMULATED.
 D. (Time) - U SC SIMULATED RELEASE OF THE EMERGENCY ACTION
 NOTIFICATION MESSAGE.
 E. (Time) - U SC ISSUED PROGRAM FEED ORDER TO U EMB.

M Y S T I C T A R G E T T E S T R E P O R T F O R M A T

6543210

DISTR:
 USAICA MAIL DESK: PLANS OFC, SCB, COMM OPS DIV {3}, LOG DIV
 AVB: WASH-4

DRAFTER TYPED NAMED, TITLE, OFFICE SYMBOL AND PHONE		SPECIAL INSTRUCTIONS DCA AND OTP VIA TELECOPIER C2, Appendix 4 to Annex H
R	TYPED NAME, TITLE, OFFICE SYMBOL AND PHONE	
E	SIGNATURE	
		SECURITY CLASSIFICATION UNCLAS

JOINT MESSAGEFORM					SECURITY CLASSIFICATION UNCLAS				
PAGE	DRAFTER OR RELEASER TIME	PRECEDENCE		LMF	CLASS	OIC	FOR MESSAGE CENTER/COMMUNICATIONS CENTER ONLY		
2 OF 2		ACT	INFO				DATE - TIME	MONTH	YR
BOOK	MESSAGE HANDLING INSTRUCTIONS								
<p>F. (Time) - WTO CIRCUITRY EXTENDED TO U EMB AT TV STUDIO. (Use on HF radio tests only.)</p> <p>G. (Time) - U EMB INFORMED (WTO/U SC) THAT EBS PROGRAM EQUIPMENT WAS ACTIVATED FOR AN EBS MYSTIC TARGET TEST.</p> <p>H. PROGRAM WAS RECEIVED BY USAICA OVER (telephone number or radio frequency); TALK-UP TAPE PLAYED AT (time); PROGRAM COMPLETED AT (time).</p> <p>I. (Time) - WTO TERMINATED EBS MYSTIC TARGET TEST.</p> <p>2. ELAPSED TEST ACTIVATION TIME FROM INITIATION BY WHCA:</p> <p>A. _____ MINUTES TO ACTIVATION OF EBS CIRCUITRY BY PGOC.</p> <p>B. _____ MINUTES TO CONCLUSION OF EBS MYSTIC TARGET TEST.</p> <p>3. REMARKS: (Include problems encountered, recommendations for corrective action, quality of program transmission, etc.) h</p>									
DISTR:									
DRAFTER TYPED NAMED, TITLE, OFFICE SYMBOL AND PHONE					SPECIAL INSTRUCTIONS				
R E L E A S E R	TYPED NAME, TITLE, OFFICE SYMBOL AND PHONE				C2				
	SIGNATURE								
					SECURITY CLASSIFICATION UNCLAS				

6
5
4
3
2
1
0

0

EBS 300/500 NET
ADMINISTRATIVE CONTACTS
MAILING ADDRESSES AND TELEPHONE NUMBERS

Station

500 Cdr, USAICA
300 ATTN: CCI-OD
P. O. Box 886
Winchester, VA 22601

Contact: Mr. Richmond
AUTOVON 380-5353
(202) 737-5721, x5353

501 HQ, NORAD
301 Combat Operations Center
ATTN: DCMS
Cheyenne Mt Complex, CO
80914

Contact: LTC Roland Hintgen
AUTOVON 834-3999
(303) 473-4010, x3284 or x3167

502 White House Comm. Agency
The White House
ATTN: Operations
Washington, DC 20500

Contact: Operations Officer
(202) 395-4040
AUTOVON 231-1467, x4010

503 Associated Press
302 4th Flt Comm Dept
50 Rockefeller Plaza
New York, NY 10020

Contact: Mr. Edward Fornell
(212) 262-8128

504 United Press International
303 15th Floor
360 N. Michigan Ave.
Chicago, IL 60601

Contact: Mr. Bill Ferguson
(312) 781-1600

Station

505 WTOP Radio & Broadcast House
Radio Master Control Room
40th & Brandywine Sts, NW
Washington, DC 20016

Contact: Mr. Granville Klink, Jr.
(202) 686-6125

506 American Broadcasting Co.
Radio News Room
1124 Connecticut Ave, NW
Washington, DC 20036

Contact: Mr. K. J. Scott
(202) 393-7700, x288

507 Columbia Broadcast System, Inc.
Radiotape Room - 2nd Floor
2020 M St, NW
Washington, DC 20036

Contact: Mr. J. Clucas
(202) 457-4321, x4302

508 Mutual Broadcasting System
Lower Level World Center Bldg
918 16th St, NW
Washington, DC 20006

Contact: Mr. Bill Wisniewski
(202) 785-6412

509 National Broadcasting Co., Inc.
Transmission Center
4001 Nebraska Ave., NW
Washington, DC 20016

Contact: Mr. Al Aebig
(202) 362-3077

Station

510 American Broadcast Co. News
ATTN: (Contact)
(1926/5)
7 West 66th St.
New York, NY 10023

Contact: Mr. J. F. Keating
(212) 581-7777, x7065
Mr. T. O'Brien
(212) 581-7777, x7501

511 CBS
Room 1402
524 W. 57th St.
New York, NY 10019

Contact: Ms. Marie Betzig
(212) 975-2041

512 Columbia Broadcasting System
(News)
Room 1E40
524 W. 57th St.
New York, NY 10019

Contact: Mr. Lee Otis
(212) 975-3658

513 Unassigned

514 National Broadcasting Co, Inc
Room 1606W
30 Rockefeller Plaza
New York, NY 10020

Contact: Mr. Martin Meaney
(212) 664-4444*

Station

515 AT&T Company
Operations Manager
210 Pine St. - 5th Floor
Harrisburg, PA 17101

Contact: Mr. W. P. Over
(717) 255-5850

516 United Press International
(Audio)
Room 1218
220 E. 42nd St.
New York, NY 10017

Contact: Mr. Bill Wilson
(212) 867-3994

517 American Tel & Tel Co.
Rm 403, TV Operating Center
725 13th St., NW
Washington, DC 20005

Contact: Mr. Robert E. Wright
(202) 457-3606

518 American Tel & Tel Co.
Rm 1002, TV Operating Center
85 W. Congress Pkwy
Chicago, IL 60605

Contact: Mr. Ron Matz
(312) 368-3123

519 American Tel & Tel Co.
TV Operating Center
51 Ivy St., NE, Room 309
Atlanta, GA 30303

Contact: Mr. Bob Dudley
(404) 529-8083

*Effective 28 Aug 76

Station

520 American Tel & Tel Co.
Rm 2471, N.R. General Control
32 Avenue of the Americas
New York, NY 10013

Contact: Mr. R. H. Oleksik
(212) 393-5324

521 American Tel & Tel Co.
Rm 2432, Network Operations
Center
32 Avenue of the Americas
New York, NY 10013

Contact: Mr. M. Stamm
(212) 393-5498

522 National Public Radio
2025 M. Street, NW
Washington, DC 20036

Contacts: Mr. George Geesey
Mr. Dick Cassidy
(202) 785-5445

523 American Tel & Tel Co.
Rm 916, TV Operating Center
4100 Bryan St.
Dallas, TX 75204

Contact: Mr. H. W. Sloan
(214) 745-2566

524 Pacific Tel & Tel Co.
Rm 1202, LA-AOC
434 S. Grand Ave.
Los Angeles, CA 90017

Contact: Mr. Richard Peters
(213) 621-6378

Station

525 American Tel & Tel Co.
ATTN: Ops Mgr
675 Elkton Drive
Colorado Springs, CO 80907

Contact: Mr. J. T. Elliott
AUTOVON 834-1211, x3316
(303) 636-4708

526 American Tel & Tel Co.
Washington #4 Ofc
11820 Leesburg Pike Rm 106
Herndon, VA 22070

Contact: Operations Manager
(202) 457-3206

527 Public Broadcast Service
475 L'Enfant Plaza W, SW
Washington, DC 20024

Contact: Mr. Dan Wells
(202) 488-5110

EMERGENCY BROADCAST SYSTEM
500 NET TELEPHONE NUMBERS

FOR OPERATIONAL USE

STATION		TELEPHONE NUMBERS	
NO.	LOCATION	PRIMARY	ALTERNATE
500	USAICA	AUTOVON 380-5266 (202) 737-5721 x5264	(703) 662-9201 x5264
501	ADCOM, Colorado	AUTOVON 834-3999 (303) 473-7488	AUTOVON 834-1211 x3275 (303) 473-4010, x3275
502	WHCA, Washington	AUTOVON 231-1467 x4010 (202) 395-4010	AUTOVON 231-1467 x4070 (202) 395-4070
503	AP, NY	(212) 262-8128	(212) 262-8126
504	UPI, Chicago	(312) 781-1634	(312) 781-1605
505	WTOP, Washington	(202) 686-6125	(202) 686-6100
*506	ABC, Washington	(202) 393-7700 x216	
**507	CBS, Washington	(202) 296-8750	
+508	MBS, Washington	(202) 785-6400	
509	NBC, Washington	(202) 362-3077	(202) 686-4395
510	ABC, NY	(212) 581-7777 x7515 ask for Charge Editor	(212) 787-5076
++511	CBS, NY	(212) 582-3830	(212) 975-2031
512	CBS-News, NY	(212) 586-7828	FTS 8-17-903-975 x3615 (212) 975-3615
513	unassigned		

*Closed 2200-0600 weekdays; closed Sat and Sun, 2200-0800.
 **Closed 2130-0600 weekdays; closed Sat and Sun, 2230-0700.
 +Closed 2400-0500 weekdays; closed Sat and Sun, 2400-0600.
 ++Closed 2300-0900 daily.

C2, Annex J to USAICA EBS Procedures



STATION		TELEPHONE NUMBERS	
NO.	LOCATION	PRIMARY	ALTERNATE
514	NBC, NY	(212) 582-9362	*(212) 664-4444 x2468
515	Harrisburg, PA, PGO	(717) 255-5866	
516	UPI-Audio, NY	(212) 867-3995 (rotary)	
517	AT&T TVOC, Washington	(202) 393-8378	(202) 393-8377
518	AT&T TVOC, Chicago	(312) 368-3123	(312) 368-3120
519	AT&T TVOC, Atlanta	(404) 529-8083	(404) 529-7492
520	AT&T NR Gen Con, NY	(212) 226-3130	(212) 393-6171
521	AT&T STATC, NY	(212) 393-6771 (rotary)	
**522	Nat Pub Radio Ntwk	(202) 785-5453	(202) 785-5380
523	AT&T TVOC, Dallas	(214) 745-4501	(214) 821-0507
524	PT&T LA-AOC, LA	(213) 621-6468 (rotary)	(213) 621-6378
525	AT&T, NCMC	AUTOVON 834-1211 x3317	
+526	AT&T, WASH-4	(202) 457-3206	(202) 737-5721 x5741
527	Pub Broadcast Svc	(202) 488-5147	

*Effective 28 Aug 76.

**Open 0700-2230 weekdays; 1200-2030, Sat and Sun.

+Open 0800-1630 Mon through Fri.

LA-AOC - Los Angeles Audio Operating Center
 NR - Network Radio
 NCMC - NORAD Cheyenne Mountain Complex
 PGO - Program Operations Center
 STATC - Status Center
 TVOC - Television Operating Center

EBS CONTACTS
(GOVERNMENT PROCEDURES)

Organization: Office of Telecommunications Policy, Executive
Office of the President

Contact: LTC John T. Taylor, USAF

Telephone: IDS 103-4876
Commercial (202) 395-4876

Address: Office of Telecommunications Policy
Executive Office of the President
Washington, DC 20504

Organization: White House Communications Agency

Contact: LTC Edward E. Nelson/CWO Leonard Stephens

Telephone: IDS 104-4040
Commercial (202) 395-4040
AUTOVON 231-1467, x4040

Address: Commander, WHCA
The White House
Washington, DC 20500

Organization: Federal Communications Commission

Contact: Emmett B. Kitchen

Telephone: IDS 101-27007
Commercial (202) 632-7007

Address: Engineering Assistant to
Commissioner Charlotte T. Reid
Federal Communications Commission
1919 M Street, NW
Washington, DC 20554

Contact: Raymond W. Seddon

Telephone: 632-7232
IDS 101-27232

Address: Chief, Emergency Communications Division
Federal Communications Commission
1919 M Street, NW
Washington, DC 20554

(For authenticators, use above address, ATTN: Art Radice,
Room A201)

Contact: Donald Aines (Mailing of FCC Publications)

Telephone: IDS 101-27232
Commercial (202) 632-7232

Address: Emergency Communications Division
Federal Communications Commission
1919 M Street, NW
Washington, DC 20554

Organization: National Security Agency

Contact: Mrs. Doris Pollock

Telephone: Commercial (202) 688-8114
AUTOVON 235-8114

Address: Director, National Security Agency
ATTN: S14
Ft Meade, MD 20755

Organization: American Telephone & Telegraph Company

Contact for Government Communications: Mr. Robert L. Wright

Telephone: Commercial (202) 466-4093

Address: American Telephone & Telegraph Company
2055 L Street, NW
Washington, DC 20036

Contact for Harrisburg PGO (NIAC Order 2): Mr. W. P. Over

Telephone: Commercial (717) 255-5850

Address: AT&T Company
Mr. W. P. Over
Operations Manager
210 Pine Street - 2nd Floor
Harrisburg, PA 17101

Organization: Aerospace Defense Command

Contact: LTC Roland L. Hintgen/MAJ Carlos Harlow

Telephone: AUTOVON 834-3999/1211, x3275
Commercial (303) 473-7488

Address: HQ, North American Air Defense
Combat Operations Center
ATTN: DCMS
Cheyenne Mountain Complex, CO 80914

Organization: U. S. Army Interagency Communications Agency

Contacts: Mr. F. James Richmond
Mr. William A. Salyan

Telephone: IDS 163-5353
AUTOVON 380-5353
Commercial (202) 757-5721, x5353

Address: Commander
U. S. Army Interagency Communications Agency
ATTN: CCI-OD
P. O. Box 886
Winchester, VA 22601

HEADQUARTERS
U.S. ARMY INTERAGENCY COMMUNICATIONS AGENCY
POST OFFICE BOX 886
WINCHESTER, VIRGINIA 22601

CCI-OD

1 Dec 75

SUBJECT: Emergency Broadcast System Procedures

TO: See Distribution

1. The attached procedures provide direction for USAICA elements in fulfilling USAICA responsibilities with respect to the Emergency Broadcast System. Sufficient background information has been included to furnish perspective to the user. The contents are based primarily on the guidance contained in the listed references. Any intended departure from these references is a result of informal coordination with WCD/DCA or the Office of Telecommunications Policy.
2. Corrections, additions, or deletions should be immediately brought to the attention of this agency, ATTN: CCI-OD.
3. These procedures are furnished to elements outside USAICA for informational purposes only.
4. Emergency Broadcast System Procedures published by USAICA on 24 April 1975 are rescinded by this publication.

1 Incl
EBS Procedures

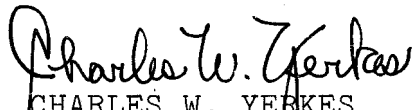
CHARLES W. YERKES
Colonel, Signal Corps
Commanding

This marking is CANCELED when separated
from material bearing a protective marking

FOR OFFICIAL USE ONLY

DISTRIBUTION

USAICA	
Cdr	1
Tech Dir	1
SCB	1
Comm Ops Div	6
CCB	1
STAB	1
AVB	1
COMSEC Div	1
Log Div	1
EMB	1
Plans Ofc	1
7th Sig Comd	1
WCD/DCA	2
GSA	
FPA	3
FPA/WVOO	1
WHCA	1
ADCOM	3
OTP	1
AT&T	
WASH-1	1
WASH-4	1
Harrisburg PGO	1
	<u>31</u>



RECORD OF CHANGES

Identification of Change	Date Entered	Signature of Person Making Entry

U S A I C A E B S P R O C E D U R E S

TABLE OF CONTENTS

	<u>Para</u>	<u>Page</u>
Glossary of Terms		vi
Purpose	1	1
References	2	1
General	3	1
Concept of Operations	4	2
Procedures	5	4
Control of EBS Teletypewriter Tapes	6	6
Preparation of Teletypewriter Tapes	7	7
Dedicated EBS Circuitry	8	10
Authenticators	9	11
Tests	10	13
Contingency Procedures	11	17
Methods for Contacting USAICA and ADCOM	12	18
Programming Through USAICA	13	18
Check Lists	14	18
Reports	15	18
FCC-issued SOP's	16	19
500 Net Addresses and Telephone Numbers	17	19
Responsibilities	18	19
Trouble Reporting	19	20

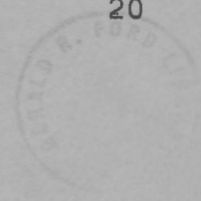

	<u>Para</u>	<u>Page</u>
USAICA 500 Net Safeguards	20	20
ADCOM Training.	21	20
Notifications	22	20
	<u>Appendix</u>	<u>Annex</u>
Check Lists of Actions. (PUBLISHED SEPARATELY)		A
Actual EBS Activation.	1	
Actual EBS NIAC Order Change	2	
Actual EBS Termination	3	
EBS Closed Circuit Test Activation	4	
EBS Closed Circuit Test Termination.	5	
Transfer of EBS Action from USAICA to ADCOM/From ADCOM to USAICA.	6	
Modified EBS Tests	7	
EBS ICE HOUSE Tests.	8	
EBS Backup Telephone Procedures.	9	
Establishing USAICA EBS Program Feed	10	
EBS MYSTIC TARGET Procedures.	11	
500 Net Station Priorities	12	
500 Net Acknowledgement Failures	13	
Preparation of Teletypewriter Tapes (PUBLISHED SEPARATELY)		B
EBS Actual Activation.	1	
EBS Actual Termination	2	

	<u>Appendix</u>	<u>Annex</u>
EBS Actual NIAC Order Change	3	
EBS Closed Circuit Test Activation	4	
EBS Closed Circuit Test Termination.	5	
EBS Weekly 500 Net Test.	6	
EBS "Please Acknowledge" Message	7	
EBS 300 Net (Telephone Routing)		C
EBS 500 Net (Teletypewriter).		D
Primary Circuit Routing.	1	
Backup Circuit Routing	2	
NIAC Order 1 and 2 Circuitry.		E
500 Net ASR Training.		F
Alternate Methods for Contacting USAICA/ ADCOM/WHCA.		G
Reports		H
300/500 Net Administrative Contacts Mailing Addresses and Telephone Numbers		I
500 Net Operational Telephone Numbers		J
EBS Contacts (Government Procedures). (LIMITED DISTRIBUTION)		K



GLOSSARY OF TERMS

- ADCOM - Aerospace Defense Command. Located at Colorado Springs, Colorado, ADCOM is the U. S. element of the North American Air Defense Command (NORAD). It is staffed by personnel from all of the military services.
- Attention Signal - The signalling arrangement whereby standard, FM, and television broadcast stations can activate muted receivers for the receipt of emergency cueing announcements and broadcasts.
- EAN - Emergency Action Notification. The order to activate the national-level Emergency Broadcast System.
- FCC EBS Check List - A document issued by the FCC which must be posted at broadcast operating positions of participating radio and TV broadcast stations. It states, in summary form, the actions to be taken by that station's personnel upon receipt of the Emergency Action Notification, Termination, or Test Messages.
- ICE HOUSE - The nickname identifying the procedures exercised by WHCA/ADCOM/USAICA to implement the Weekly 300/500 Net Equipment Tests.
- MYSTIC TARGET - The nickname identifying tests simulating a program transmission from the WHCA Trip Officer through USAICA program facilities into the NIAC 1/2 circuitry.
- NIAC - The National Industry Advisory Committee as used herein is a committee appointed by the FCC to advise and assist the commission in a number of areas including establishing the Emergency Broadcast System. This group is made up of technical representatives, programming representatives (news), and others as required from the broadcasting industry.

NIAC/NNC (600 Net)
[National News
Radio/Press Wire
Message Authent-
ication and Distri-
bution System]

- A teletypewriter system established to provide multiple entry from the USAICA COMMCEN through New York City and Atlanta, GA, into Associated Press and United Press International Radio/Press Services to allow for the rapid, widespread dissemination of official government news releases to subscribers of the respective services. This system may be used as an alternate method of transmitting the EAN to AP/UPI in the event other methods are not operational.

NIAC Order

- A pre-positioned service order filed with the American Telephone and Telegraph Company providing for advance arrangements for program origination reconfiguration of the major radio and television landline broadcast networks voluntarily participating in the Emergency Broadcast System.

NIAC Order 1/2
Circuitry

- Established audio circuitry which interconnects WHCA; USAICA; WTOP, Washington, DC; and Harrisburg, PA (AT&T TVOC). Programs can be originated at or through WHCA (CROWN) or USAICA. Entry into WTOP would be NIAC Order 1; through Harrisburg, NIAC Order 2.

NIAC Orders
101-106

- Configurations of the national program networks to provide entry at specified AT&T locations each designated by a number. These NIAC orders are used exclusively for last resort purposes and involve only WHCA and AT&T:

NIAC Order 101	AT&T Control Atlanta
102	AT&T Control Washington, DC
103	AT&T Control New York

104	AT&T Control Chicago
105	AT&T Control Los Angeles
106	AT&T Control Dallas

300 Telephone
Net

- This dedicated net interconnects AP-New York, UPI-Chicago, ADCOM, and USAICA with a single loop. Any station can signal the entire net by transmitting a broadcast signal or by selecting each station individually. Only one conversation is possible at one time. Each station is identified by a three-digit number beginning with 300. The 300 Net is used to validate 500 Net transmissions.

500 Teletypewriter
Net

- A dedicated teletypewriter net used for passing EBS Activation (EAN and NIAC Order number), Termination, and NIAC Order Change information. Receive-only terminals are provided selected activities in the broadcast networks, AP/UPI, and AT&T. A send terminal is installed at each EBS origination point (USAICA/ADCOM) which provides for broadcast (or selected station) transmissions and automatic polling of acknowledgements. Each terminal is identified by a three-digit number beginning with 500.

Last Resort
Procedures

- If national communications capabilities have been severely reduced, making normal activation doubtful, this method may be used. The WHCA Trip Officer uses whatever telephone capability available to call the AT&T Control Center in Atlanta, Washington, New York, Chicago, Los Angeles or Dallas until communications are established. The first call should be made to the location nearest to the location of the Trip Officer. After authentication, AT&T personnel take action to configure the selected NIAC Order Number. The WHCA Trip Officer reads the EAN two times over the

established program channel and initiates the standard procedures for the Presidential message. The WHCA Trip Officer effects termination by reading the emergency action termination message over the program channel two times. Since USAICA is not involved in these procedures no details are included in this document (see FCC SOP 3).

EMERGENCY BROADCAST SYSTEM PROCEDURES

1. Purpose: To identify USAICA responsibilities with respect to the National Level Emergency Broadcast System (EBS) and to formalize procedures for fulfillment thereof.

2. References:

a. Emergency Broadcast System Procedures Manual, January 1974, published by the Office of Telecommunications Policy, Executive Office of the President.

b. FCC Rules and Regulations Part 73 - Radio Broadcast Services, Subpara G - Emergency Action Notification System and the Emergency Broadcast System.

c. FCC EBS Standard Operating Procedures, 15 March 1974:

(1) SOP 1 - EBS Activation and Termination Procedures.

(2) SOP 2 - EBS Test Procedures.

(3) SOP 3 - EBS Backup Procedures.

d. FCC EBS Checklist Primary and Alternate Stations, 1974.

e. DCA message, DCA 512.4, 10 January 1967, subject: Modified Testing of the EBS (filed in Comm Ops Div).

f. Continuity of Government Operations Plan for Providing Emergency Presidential Communications Interface (High Frequency Radio) (U), 1 January 1975, published by the Office of Preparedness, General Services Administration.

3. General:

a. System Description. The National-level EBS, when activated, consists of a nationwide network of voluntary participating radio and television (audio only) stations interconnected by Telephone Company circuitry. These stations are issued EBS Authorization by the FCC. The system is designed to maintain communications with the general public in the event of an attack, a threat of war, a state of public



peril, disaster, or other national emergency. Each EBS station assumes the responsibility for serving a specifically designated area known in the EBS as an "Operational Area" with, not only local area instructions, news, and information, but also with Presidential messages, Governors' messages, and State information, as well as national programming and news.

b. Activation Authority. The authority to activate the National Level Emergency Broadcast System rests solely with the President of the United States.

4. Concept of Operations:

a. Activation. In order to activate the National Level EBS (hereafter referred to as the EBS), the following actions are required:

(1) A Presidential decision to activate which is passed to the White House Communications Agency (WHCA) for implementation.

(2) The selection by WHCA of an activation order origination point. The following activities are technically capable of relaying activation (and other) orders to the broadcast industry (does not apply to last resort procedures - see FCC SOP 3):

(a) Aerospace Defense Command (ADCOM), Colorado Springs, CO.

(b) U. S. Army Interagency Communications Agency (USAICA).

(3) By telephone, WHCA will furnish the selected origination point with the location the program feed will enter the national broadcast networks. This location is identified as a NIAC Order number (see Glossary of Terms).

(4) The selected origination point, using a dedicated teletypewriter net (500 Net) providing confirmation with a dedicated telephone net (300 Net), relays activation order (Emergency Action Notification - EAN and NIAC Order Number) information to three general groupings of the communications industry:

(a) Broadcast Networks. ABC, NBC, CBS, MBS, NPR, PBS, and UPI-audio, using network alerting facilities, retransmit the EAN to their affiliates.

(b) Press Wire Services. Associated Press (AP) and United Press International (UPI) relay the Emergency Action Notification (EAN) over their radio wire networks alerting those broadcast stations having AP/UPI teletypewriter terminals of the impending EBS activation. The broadcast stations take actions prescribed by the FCC EBS Checklist issued to broadcast stations in preparation for the Presidential broadcast.

NOTE: All broadcast licensees are required to install, maintain, and operate radio receiving equipment for receipt of the Emergency Action Notification (EAN) or Emergency Action Termination (EAT). Stations receiving this information via the radio wire services or through network alerting are required to broadcast it to enable other stations to learn of the EAN or EAT by off-the-air monitoring.

(c) The Telephone Company will, upon receipt of the NIAC Order request contained in the activation instructions, configure national program circuitry connecting all participating network and independent radio and television stations. This circuitry is arranged to accept a program feed from a specific entry point identified with the NIAC Order number provided.

b. Programming. WHCA will arrange for circuitry into the appropriate NIAC Order entry point. USAICA is not involved unless the Presidential broadcast originated at or passes through the FPA/SF. Such a condition could exist only under a NIAC Order 1 or 2. Detailed information is provided elsewhere in these procedures.

c. Termination. When the national level EBS is no longer needed, a termination order is issued. The sequence of events closely parallels that for activating the EBS.

(1) A Presidential decision to terminate the EBS is passed to WHCA for implementation.

(2) WHCA selects the termination order origination point, USAICA or ADCOM, and telephones the termination order.

(3) The origination point transmits an Emergency Action termination message over the 500 Net Teletypewriter Net and confirms its authenticity with AP/UPI over the 300 Telephone Net.



(4) AP/UPI transmits the termination order over their radio wire networks; the broadcast networks notify their affiliates via network alerting facilities.

(5) AT&T restores the program circuitry to network control.

d. NIAC Change Orders. It may be necessary to transfer the entry point for EBS programming after the system has been activated. The sequence of events is similar to an activation/termination order except that since only the program feed is affected, the broadcast stations are not notified.

(1) A Presidential decision to move the point of EBS program entry into the national network is passed to WHCA for implementation.

(2) WHCA selects an origination point, USAICA or ADCOM, for releasing the NIAC Change Order and issues necessary instructions by telephone.

(3) The selected origination point transmits a NIAC Change Order over the 500 Teletypewriter Network and confirms its authenticity with AP/UPI using the 300 Telephone Net.

(4) AT&T reconfigures the national program network to accept a feed at the new entry point.

e. Under extreme conditions where the aforementioned concepts are not feasible, WHCA may communicate directly with the AT&T program entry point and attempt to establish the EBS without recourse to either ADCOM or USAICA.

f. Testing. Government and industry procedures and equipment used in EBS actions are tested regularly. Details are contained elsewhere in these procedures.

g. Authentication. All messages, both telephonic and teletype from WHCA and USAICA/ADCOM, are authenticated with specially issued lists.

5. Procedures: USAICA procedures for processing EBS actions fall into two broad categories: actual EBS actions and EBS tests.

a. Procedures related to EBS testing is found elsewhere in these procedures.

b. Actual and simulated EBS activations, terminations, and NIAC Change Orders comprise fairly parallel procedures. Outlined below is a summary of the actions contained in the USAICA check lists (Annex A, published separately):

(1) WHCA Trip Officer (WTO) telephones the USAICA Systems Controller (USC) using entry established by procedures.

(2) WTO and USC validate identity by authenticators (challenge and response).

(3) WTO issues instructions which are repeated back by U SC. U SC refers to appropriate check list, using it as a work sheet.

(4) U SC attempts to retain WTO on telephone.

(5) U SC, using dial intercom, calls the USAICA COMMEN Section Chief (U CMC) and passes instructions for the appropriate EBS action. No authentication procedures are used. U CMC refers to appropriate check list using it as a work sheet.

(6) U CMC selects appropriate authenticator which he provides the U SC. The U SC must confirm the accuracy of this authenticator.

(7) U CMC orders release of appropriate authenticated teletypewriter tape over the 500 Net. As soon as the tape has started, he informs the U SC.

(8) U SC conferences the 300 Net and informs AP, UPI, and ADCOM of the particular EBS action in process. He insures that all are receiving the message. If either AP or UPI (or both) are not receiving the message, the U SC makes a decision whether ordering the U CMC to retransmit the message, to ask ADCOM to assume responsibility, or to read the message over the telephone.

(9) The 500 Net teletypewriter tape contains automatic stops for entering authenticator words, date and time, NIAC

Order No., and a stop as a safeguard against the possibility of unintentional release of the wrong tape. Tapes are color-coded for ready identification.

(10) At the completion of the 500 Net transmission, the terminal stations are polled for acknowledgements. Acknowledgement is performed by operating a key at each receive-only (RO) terminal. The sending station (USAICA or ADCOM) will poll three times. A short service message is then transmitted to those stations not having responded asking them to "Please Acknowledge." Simultaneously, COMMCEN personnel begin telephoning the delinquent stations while the 500 Net send terminal continues to poll. If either AP or UPI is among the delinquent stations, the U CMC asks the U SC to seek acknowledgement via the 300 Net.

(11) If the WTO has been held on the telephone circuit, he will be given periodic status reports. If not, he will be notified only upon failure to obtain acknowledgements from one of the nine critical stations on the 500 Net. These stations are identified in Annex A. In any event, the U CMC keeps the U SC aware of the status of actions.

(12) U SC notifies N3WC of completed action.

(13) U SC notifies other elements in USAICA and FPA/WVOO of actions taken.

c. The aforesaid procedures are intended only to provide an overview and do not include all the alternatives available.

6. Control of EBS Teletypewriter Tapes:

a. USAICA maintains six pre-cut EBS teletypewriter tapes which are color-coded for quick and positive identification. The tape, the reel on which the tape is wound, and the can in which the reel is stored are all of the same color. The identity of the tape is posted adjacent to the reel storage can, on the face of the reel, and on the tape leader.

b. All actual (live) EBS tapes and EBS Closed Circuit Tapes are located in a storage cabinet behind the 500 Net AS/R. The live EBS tapes and the EBS Closed Circuit Test Tapes are segregated in two compartments. Each compartment is secured by two different locks making a total of four different locks. Two different keys are required to open each side of the cabinet for a total of four different keys.

c. The Section Chief will maintain on his person one key for each compartment; the person assigned as EBS Operator will maintain on his person the other key for each compartment. These keys must not leave the COMMCEN. If the Section Chief must leave the COMMCEN, he will turn his set of keys over to the Assistant Section Chief. If the EBS Operator must leave the COMMCEN, he will turn his set of keys over to the Alternate EBS Operator. Under no condition will one employee retain both sets of keys.

d. The EBS 500 Net Weekly Test Tape will not be secured in this cabinet but will be mounted on the wall adjacent to the cabinet. This tape, as well as its reel and can, will be color-coded and identified in a manner similar to the other tapes.

e. The U CMC will have all EBS tapes, cabinet keys, and spare keys inventoried at the beginning of each shift, and will include an entry to this effect in the Team Chief's Log. It will be necessary at the beginning of each shift to assign an EBS Operator and alternate. One of these employees will operate the EBS 500 Net AS/R in the event an EBS action occurs during that shift. The names of these operators will be posted on the shift schedule. The spare set of keys for the EBS Tape Cabinet will be kept in the Duty Section Chief's safe drawer.

7. Preparation of Teletypewriter Tapes. In order to insure uniformity, CCB normally prepares tapes for both USAICA and ADCOM. Tapes are color-coded for identification and are prepared on MYLAR stock. Each live tape and closed circuit test tape have an automatic stop function in the heading which requires manual intervention between the start of transmission and the text of the order. Five of the six tapes require entry of authenticators. Because the Red Envelope provides different "live" authenticators for each day, the entry is made at the time of transmission. Although there is only one test authenticator per month, in order to preserve realism, it is also entered during transmission. It will be noted that a one-minute pause has been provided between the two messages contained in each "activation" tape. The pause is intended to provide time for the broadcast networks to use their internal alerting systems to transmit the EAN to their affiliate stations before the AT&T reconfigures the program network. Transmit times include entry of information. (See Annex B for tape preparation instructions, published separately.) One-inch mylar stock is used for all pre-cut EBS tapes.

a. EBS Activation Tape:

Color - red.

Contents - EAN message, one-minute pause, NIAC Order message.

Automatic stops - 7.

"Check Tape" safeguard - once.

Authenticator words - twice in EAN, once in NIAC Order message.

Date/Time - once in each message.

NIAC Order - once in NIAC Order Message.

Average transmit time - 4 minutes, 5 seconds*

b. EBS Termination Tape:

Color - green.

Contents - one message.

Automatic stops - 4.

"Check Tape" safeguard - once.

Authenticator words - twice.

Date/Time - once.

Average transmit time - 1 minute, 25 seconds*

c. EBS NIAC order Change Tape:

Color - blue.

Contents - one message.

Automatic stops - 5.

"Check Tape" safeguard - once.

*Does not include "Please Acknowledge" message.

NIAC Order terminated - once.

NIAC Order implemented - once.

Authenticator words - once.

Date/Time - once.

Average transmit time - 1 minute, 25 seconds*

d. EBS Closed Circuit Test Activation Tape:

Color - white

Contents - simulated EAN message, one-minute pause,
simulated NIAC Order message.

Automatic stops - 9.

"Check Tape" safeguard - once.

Program Time - once in simulated EAN.

Authenticator words - twice in simulated EAN;
once in NIAC Order message.

Date/Time - once in each message.

Program time - once in NIAC Order message.

NIAC Order - twice in NIAC Order message.

Average transmit time - 5 minutes, 45 seconds*

e. EBS Closed Circuit Test Termination Tape:

Color - black.

Contents - one message.

Automatic stops - 5.

"Check Tape" safeguard - once.

Authenticator word - twice.

*Does not include "Please Acknowledge" message.

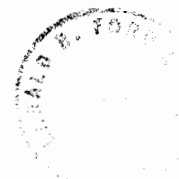

Termination time - once.

Date/Time - once.

Average transmit time - 1 minute, 50 seconds*

f. EBS 500 Net Weekly Test Tape:

Color - yellow.

Contents - two parts.

Instructions in case of technical trouble.

EAN test.

Automatic stops - 1.

Date/Time - once in part 2.

Average transmit time - 2 minutes, 10 seconds*

g. "Please Acknowledge" Message:

Color - not applicable; punched in the end of each of the aforementioned tapes to alert delinquent stations.

Contents - one message explaining the operation of the acknowledgement key (see Annex A, Appendix 12).

Transmit time - 35 seconds.

8. Dedicated EBS Circuitry: Dedicated telephone and teletypewriter networks have been installed to permit ADCOM or USAICA to relay EBS actions (e.g., activation, termination, etc.). Specifically, they are identified as the 300 Telephone Network and the 500 Teletypewriter Network (hereafter referred to as the 300 Net and 500 Net). In addition, separate circuitry is permanently wired to provide for a NIAC Order 1 or 2 program feed.

a. 300 Net - This automatic-ring telephone system has terminals at USAICA (Station 300); ADCOM (Station 301); AP,

*Does not include "Please Acknowledge" message.

New York (Station 302); and UPI, Chicago (Station 303). Each terminal has the capability of conferencing the entire net or signalling each of the other terminals individually. Only one telephone conversation is possible at any one time. The primary purpose of the 300 Net is to provide a means of voice confirmation to the AP/UPI control points that an EAN concurrently transmitted via teletypewriter over the 500 Net is authentic. (See Annex C.)

b. 500 Net - This multipoint, 100 WPM, teletypewriter system consists of two send-receive (Model 28 ASR) terminals (ADCOM and USAICA) and some 25 receive-only (Model 28 RO) terminals located in various press wire service, broadcast networks and telephone company facilities. Because each station is identified by a 3-digit code beginning with Station 500, it is known as the 500 Net. The ASR terminals are equipped for broadcast, individual, or groups of station selection and for automatic polling. The RO terminals are equipped with audible and visual alarms and answer-back generators which are controlled by operating a key. Automatic polling of RO stations by the sending ASR after message transmissions provides a means for obtaining acknowledgements. The primary purpose of the 500 Net is to transmit EAN's, NIAC Orders, NIAC Change Orders, etc., to the wire services, the broadcast industry and the telephone company. (See Annex D.)

c. NIAC Order 1 and 2 Circuitry - This circuitry permits the insertion of an EBS program into the national program circuitry via Radio Station WTOP, Washington, D.C. (NIAC Order 1), or the AT&T Test Center, Harrisburg, PA (NIAC Order 2). Permanently wired, the circuitry can accept a program origination from the White House, Washington, DC, or USAICA. (See Annex E.) USAICA continuously feeds a 400 Hz tone over this circuitry when it is idle. A tone detector at USAICA will ascertain circuit continuity. When a NIAC Order 1 or 2 is ordered, the tone must be removed; when terminated the tone must be restored. This action is part of the USAICA check list of actions (Annex A). When ADCOM is the origination point involving a NIAC Order 1 or 2, ADCOM will so notify the USAICA Systems Controller via the 300 Net. The USAICA COMMCEN Section Chief will also notify the USAICA Systems Controller when an ADCOM-originated message is received on the 500 Net.

9. Authenticators: Four separate authenticator lists are provided for implementing EBS actions, both actual and test.

a. EBS Initiation Authenticator List (U) (WHCA 1). Issued semiannually (May-Oct/Nov-Apr), this authenticator list, classified CONFIDENTIAL, is issued to WHCA, ADCOM, and USAICA (two copies). The list provides for telephone challenge and response by WTO and ADCOM or USAICA. The primary purpose of this list is to authenticate between WHCA and the origination point chosen; however, USAICA and ADCOM may use the list independently of WHCA during contingency transfer of actions. The digraph authenticators (two letters) are declassified on use. Thirty-six sets of authenticators are provided for actual EBS actions and 36 different sets for test actions. In USAICA, one authenticator envelope is kept with the Systems Controller EBS instructions; the other copy is in his safe. The White House Communications Agency (WHCA) is the proponent authority for this list.

b. EBS Authenticator List (Red Envelope). Issued semiannually (Jan-Jun/Jul-Dec), in three copies to USAICA, this authenticator is marked FOR OFFICIAL USE ONLY. With respect to live EBS actions, the list contains a different set of authenticator digraphs for each day in the period; one digraph for activation; one, for termination. In the case of a NIAC Change Order, an "activation" word is used. In the unlikely event of two activations or an activation and a NIAC Change Order occurring on the same day, the same authenticator will be used. These authenticators are entered in the teletypewriter messages at the time of transmission over the EBS 500 Net. If it is necessary to read the message by telephone, the authenticator will be included. For this reason, it is mandatory to retain a list in the U SC EBS instructions. Additionally, the U SC must confirm the proper authenticator to be used by the COMMCEN. The other two copies are retained in the COMMCEN EBS cabinet. This authenticator list (hereafter called the Red Envelope) contains six sets of test authenticators on the outside of the envelope, one set for each month in the period. If there is a requirement for the use of more than one test authenticator during a single month, the same digraphs will be used. In the COMMCEN EBS Cabinet, one red envelope is stored with the "live" EBS tapes; the other with the Closed Circuit Test EBS tapes. The envelope stored with the Closed Circuit Test tapes will have the inside "live" authenticator list removed. The proponent authority for the Red Envelope is the Federal Communications Commission, who also issues it to each broadcast station and to all stations in the 500 Net.

c. Emergency Broadcast System Authentication List (Voice) (U). This list, hereafter referred to as the Voice Back-up, is intended to provide challenge and response if implementation of the telephone back-up procedures becomes necessary because of failure of the 500 Net. The Voice Back-up List is issued semiannually (Jan - Jun/Jul - Dec) by the FCC who is also the proponent authority. There are no test authenticators on this Voice Back-up List. The list contains 31 sets of digraphs (one digraph for challenge; one, for response). The set corresponding to the day of the month is used. A complete description of the Back-up Telephone Alerting and Authentication Procedures is found elsewhere in this document. Two copies of this authenticator list are kept in COMMCEN--one copy in the EBS cabinet; one copy in the file. The third copy is kept in the U SC with the EBS instructions.

d. NIAC 2 Authenticators. This list, marked FOR OFFICIAL USE ONLY, is prepared and issued by Comm Ops Div semiannually (Jul - Dec/Jan - Jun) in three copies--one to AVB, one to SCB, and one to the AT&T Television Operations Center (TVOC), Harrisburg, PA. The purpose of the list is to permit the TVOC to validate a telephone request from USAICA to accept an EBS program feed over the NIAC 2 circuitry and extend it over the national networks. The list contains 12 sets of authenticator words, each set consists of one challenge word and one response word. The sets are divided--six for live activation or NIAC Change Order and six for Closed Circuit Tests. When one set is used, it is lined out. No relationship exists between a set of authenticators and any particular month. (See Appendix 10, Annex A.)

10. Tests: USAICA participates in a number of tests and exercises aimed at insuring operational readiness of personnel and equipment associated with the EBS. These tests include:

Closed Circuit Tests	NIAC 1/2 Circuitry Tests
Modified EBS Tests	500 Net Polling Tests
ICE HOUSE Tests	500 Net ASR Training
MYSTIC TARGET Tests	In-house Tests

a. Closed Circuit Tests:

(1) Exercise government and industry EBS activation and termination procedures.

(2) Insure equipment in the 300/500 Net is operational.

(3) Provide for an audio program to be originated by WHCA, fed into and through the national networks, and received by network radio stations (TV stations do not participate). This program is not broadcast over the air. (See Annex A, Appendixes 4 and 5.)

(4) SCB prepares formal reports of tests in which USAICA is the origination point except when action is transferred to ADCOM by Contingency Procedures (Appendix 6 to Annex A).

b. Modified EBS Testing is not a requirement of OTP, FCC, or WHCA. This testing was originally required by the Office of Emergency Planning (now FPA) (see reference 2d) and simulates the origination of an EBS audio program at a DCPA Region which is transmitted to USAICA via HF radio later switched to AUTOVON during the test. EBS activation and termination procedures are not exercised. Two circuits are, therefore, established--one radio circuit for the program and one AUTOVON circuit for cueing and control and for program transmissions during the switch. The test consists of a five minute talk-up and a four and one-half minute program which is recorded at USAICA for evaluation purposes. AVB prepares a formal report within three working days of the last test of the month explaining any failures occurring in the course of the month's testing. A negative report is not required.

(1) Tests with each DCPA Region are scheduled once each month as follows:

1st Monday of the month	Region 1
1st Thursday of the month	Region 2
2nd Monday of the month	Region 3
2nd Thursday of the month	Region 4
3rd Monday of the month	Region 5
3rd Thursday of the month	Region 6
4th Monday of the month	Region 7
4th Thursday of the month	Region 8

NOTE: Tests which fall on legal holidays are rescheduled by SCB.

(2) A check list of actions for conducting a Modified EBS Test is attached as Appendix 7 to Annex A.

c. ICE HOUSE Tests:

(1) WHCA initiates at random times a weekly 300/500 Net equipment test with either ADCOM or USAICA acting as origination point. During these tests, WHCA and ADCOM/USAICA also test the government activation procedures. To avoid the possibility of confusing these tests with live activation procedures or Closed Circuit Tests, the nickname "ICE HOUSE" is used.

(2) After-action reports of equipment tests conducted by USAICA will be prepared by SCB for receipt by the addresses within two normal duty days of the test. Appendix 2 to Annex H prescribes the format. Such reports will be sent to OTP for action, info WHCA, ADCOM, FCC, and WCD/DCA, with the same internal addressee as the test schedules. The USAICA reports should contain other information relative to maintenance problems of sufficient gravity to warrant making a formal record. As an example, information that certain stations had turned off their RO terminals should be included even though such an incident may have happened several days prior to the weekly test.

(3) A check list of actions for conducting the weekly 300/500 Net equipment test (ICE HOUSE) is contained in Appendix 8 to Annex A.

d. MYSTIC TARGET Tests:

(1) WHCA (actual or simulated) will initiate weekly tests to insure USAICA readiness to accept a program feed and patch this feed into the NIAC 1/2 circuitry to the AT&T PGO, Harrisburg, PA. These tests are nicknamed "MYSTIC TARGET".

(2) Tests will encompass entry to USAICA via TelCo circuitry or via government radio.

(3) A check list of actions for conducting MYSTIC TARGET Tests is contained Appendix 11, Annex A.

(4) After-action reports of MYSTIC TARGET Tests conducted will be prepared by AVB with input by STAB, CCB, SCB and EMB. Such reports will be sent to OTP for action, info WHCA and WCD/DCA. See Appendix 4 to Annex H for message format.



e. NIAC Order 1 and 2 circuitry is tested as follows:

(1) Once each duty day AVB connects a monitor speaker on feed-back circuits. Pickup of the 400 Hz tone insures circuit continuity.

(2) AVB coordinates with SCB and WHCA in testing the NIAC 1/2 circuits weekly on Mondays at approximately 1000 hours, local time. The receive circuit of NIAC 2 is checked for proper levels (0 Db). An additional 1000 Hz tone is transmitted on NIAC 1 and checked on the receive circuit for proper levels. The additional 1000 Hz test tone will be removed from NIAC 1 circuit on completion of the test.

(3) In addition to normal trouble reporting procedures, outages or degradation of the NIAC Order 1 and 2 circuitry will be reported immediately to the WHCA Duty Officer by SCB.

(4) Information on the weekly NIAC Order 1 and 2 circuitry tests will be included in the 300/500 Net Equipment Test Report prepared by SCB. AVB will furnish the information to CCB, who will incorporate with their input to SCB after the next ICE HOUSE Test.

f. 500 Net Polling Tests are conducted by the U CMC once every shift. This test is passive in that no terminal alarms are activated. Immediate indications of circuit or equipment problems are provided by any failure to receive an answer-back. U CMC should immediately report troubles to the U SC.

g. 500 Net ASR training is conducted once each tour (nominally one week) for each COMM-CEN operator and supervisor. This training is accomplished by patching the USAICA ASR off-net. Each operator being trained performs all the functions necessary to transmit an EBS tape to include operation of message addressor as well as polling the terminal stations. Since the ASR is terminated (patched into a dead loop), no signals leave the site. (See Annex F.) In addition to the equipment training, supervisors in SCB and CCB will conduct once each tour a review of USAICA EBS procedures for operational personnel. Supervisors in TV/R and EMB will insure that procedures for EBS programming from or through USAICA are reviewed at least once each week or tour.

h. In-house tests exercise internal USAICA actions only. They are based on either live or test actions; however, no telephone or teletype transmissions are made outside of USAICA. In-house tests are intended to provide some means of practice for U SC and COMMCEN personnel in the absence of ICE HOUSE, MYSTIC TARGET, or Closed Circuit Tests or for personnel who are off-shift when Closed Circuit or ICE HOUSE Tests are conducted. STAB is responsible for initiating in-house tests, for simulating the WTO, for insuring proper safeguards to prevent any transmission outside of USAICA, and for recommending to the Chief, Comm Ops Div, any corrective action. In-house tests should never be conducted without advance notice to participants. No tapes should be processed through the 500 Net ASR TD unless the equipment is removed from the line. In-house tests should exercise all types of EBS actions including the live actions. When tapes are processed (off-line) during these tests, the authenticator will always be "SIMULATE" and NIAC Order No. "NINETY." Appropriate check lists should be used where possible.

11. Contingency Procedures. These procedures are for use when an EBS action is in progress and are intended for guidance, not as a substitute for professional judgment which should always be exercised to correct an adverse situation.

a. Upon failure of one or more stations in the 300 Net, the U SC should attempt to contact AP/UPI/ADCOM using the commercial telephone network.

b. Upon failure of the 500 Net, manifested by indications of garble or acknowledgement failure, the U CMC may make an additional transmission of the affected message.

c. Upon failure of the USAICA 500 Net ASR terminal, the U CMC will notify the U SC to contact ADCOM and request the transmission responsibility be accepted by that headquarters. If the situation is reversed, ADCOM may ask USAICA to assume transmission responsibility. (See Annex A, Appendix 6.)

d. During live EBS actions only, if any or all the above steps have been attempted and over half the 500 Net stations have not acknowledged receipt of the message, the U SC should direct the U CMC to transmit the message by telephone by using the EBS Backup Telephone Procedures. (See Annex A, Appendix 9.) [NOTE: If control has been

passed to ADCOM but ADCOM is unable to release the message, control reverts back to USAICA for implementation of telephone back-up procedures.]

e. If any particular contingency permits, telephoning 500 Net stations should be in the priority shown in Annex A, Appendix 11.

12. Methods for Contacting USAICA and ADCOM. Methods for contacting ADCOM/USAICA in relative order of priority are shown in Annex G.

13. Programming through USAICA. It may be necessary for WHCA to extend the EBS program feed from the point of broadcast origination to USAICA and thence out to the national network via NIAC Order 1 or 2 circuitry. In such a case, the program feed might enter USAICA by either landline or radio. The U SC will have been alerted that the program feed will be through USAICA by the information contained in the WTO EBS activation dialogue. For the details, see Annex A, Appendix 10.

14. Check Lists. The check lists provided as Annex A to these procedures are intended for use by USAICA elements in conducting all EBS actions, both actual and test, and in associated contingencies. The check lists have been prepared as a result of internal coordination among SCB, CCB, AVB, and EMB. Appropriate portions have also been coordinated with ADCOM and WHCA. No unilateral changes should be made without thoughtful consideration of outside impact. **IT IS IMPERATIVE THAT ALL STEPS IN THE CHECK LISTS BE FOLLOWED VERBATIM UNLESS UNANTICIPATED EVENTS DICTATE A DEPARTURE.** The check lists should be used as work sheets during EBS actions and information entered where indicated. The sheets will be used for after-action reports and evaluation. Each check list is dated in the upper right-hand corner to facilitate revision.

15. Reports. At the conclusion of each action (both actual and test), formal reports will be rendered. Normally such reports will be prepared for receipt by the addressees within two working days of the activation or test. Report formats are contained in Annex H. Responsibility for preparation of reports is as follows:

<u>Action</u>	<u>Responsible Elements</u>
Live Activations	SCB
Closed Circuit Tests	SCB
Weekly 300/500 Net Tests (ICE HOUSE)	SCB
Monthly NIAC Order 1/2 Circuitry	AVB passes to CCB (include with 300/500 Net Test Report to SCB)
Modified EBS Tests	AVB
Program Feed Tests (MYSTIC TARGET)	AVB

16. FCC-issued Standard (sic) Operating Procedures. The SOP's contain detailed operational instructions which are used for activating, terminating, and testing the National-level EBS. They are issued by the FCC to specified control points of the national radio and television broadcast networks (ABC, CBS, NBC, NPR, UPI-Audio, ABC-TV, CBS-TV, NBC-TV, and PBS), the American Telephone and Telegraph Company (AT&T), the Associated Press (AP), and the United Press International (UPI). All SOP's are bound in a single publication.

a. SOP-1, EBS Activation and Termination Procedures. This SOP contains the detailed operational and authentication procedures for activation, operation, and termination of the EBS in response to an actual National emergency situation.

b. SOP-2, EBS Test Transmissions. This SOP contains the detailed operational and authentication procedures for testing the EBS.

c. SOP-3, EBS Backup Procedures. This SOP contains the detailed operational and authentication procedures to be used in event the procedures in SOP-1 cannot function.

d. Checklist for Primary and Alternate Stations. This check list provides instructions for EBS participating broadcast stations.

17. 500 Net Addresses and Telephone Numbers. 500 Net mail addresses and administrative telephone numbers are listed in Annex I. Operation telephone numbers are contained in Annex J.

18. Responsibilities. Communications Operations Division is the cognizant staff activity within USAICA for all Emergency Broadcast System staff actions.



19. Trouble Reporting. All troubles noted on the 300/500 Nets, NIAC 1 and 2 circuitry, and EBS-associated studio equipment will be reported to the USAICA Systems Controller as will requests for scheduled outages. ADCOM has agreed to support this procedure. The USAICA Systems Controller will report contractor-maintained circuitry and equipment troubles and outages as follows:

- a. 300 Net - WASH-1.
- b. 500 Net - WASH-1.
- c. NIAC 1 and 2 Program Circuitry - WASH-4 during duty hours; Leesburg-5 during other than duty hours.

20. USAICA 500 Net Safeguards. The USAICA 500 Net terminal has been provided with a transfer key with visual alarm and a receive-only printer. By operating the transfer key, the ASR is terminated from the 500 Net and patched into a dummy loop. The visual alarm indicates the ASR is off-net. The RO is connected to the line side of the AT&T frame and will print all signals leaving the site. U CMC will request authority from U SC prior to removing the ASR from the 500 Net. U SC will coordinate with ADCOM via the 300 Net and notify WTO that the ASR is off-net. After the ASR is patched off-net, the U CMC will poll the net before any tape transmissions are attempted. Absence of any answer-back codes indicates the terminal is in fact off-net and training can commence. Any indication of the USAICA RO printer operating during training will indicate transmissions are going out over the net and training will be suspended until the discrepancy can be corrected. After training has been completed, the above procedure will be reversed to restore the terminal to operational readiness.

21. ADCOM Training. When the ADCOM Systems Controller wishes to conduct 500 Net ASR training, he will contact the USAICA Systems Controller and request release. U SC will notify CCB and WTO. When its terminal has been restored to operational readiness, ADCOM will again notify the USAICA Systems Controller, who in turn will inform CCB and WTO.

22. Notifications. Upon live EBS activation, certain tests and outages, the USAICA Systems Controller will notify specified non-participants. Such notifications will be made so as not to interfere with operational considerations.

a. Live EBS Activation, NIAC Change Orders, and Terminations:

USAICA Commander/Technical Director - At all times
Director, FPA/WV00 - At all times
WCD Duty Officer - At all times
Chief, Comm Ops Div - At all times
Chief, AVB, or EMB - At all times

b. EBS Closed Circuit Tests:

USAICA Commander/Technical Director - Duty hours only
Director, FPA/WV00 - Duty hours only
WCD - Duty hours only
Chief, Comm Ops Div - At all times
Chief, AVB, or EMB - At all times

c. Weekly 300/500 Net Tests (ICE HOUSE):

Chief, Comm Ops Div - Duty hours only

d. Program Feed Tests (MYSTIC TARGET)

Chief, Comm Ops Div - Duty hours only

e. Maintenance Release of 300 or 500 Net, 500 Net ASR, NIAC 1 or 2 Circuitry:

USAICA Technical Director - Duty hours only
WHCA Duty Officer - At all times
Chief, Comm Ops Div - Duty hours only
ADCOM Systems Controller - At all times

f. Major Outage:

USAICA Commander/Technical Director - At all times
WCD - At all times
WHCA Duty Officer - At all times
Chief, Comm Ops Div - At all times
ADCOM Systems Controller - At all times
CCB Section Chief - At all times

g. Critical irregularities:

Chief or Comm Manager, Comm Ops Div - At all times
or
USAICA Commander/Technical Director - At all times



C



EBS 300 NET (TELEPHONE) ROUTING
Circuit No. 15600-001

1 OCT 75

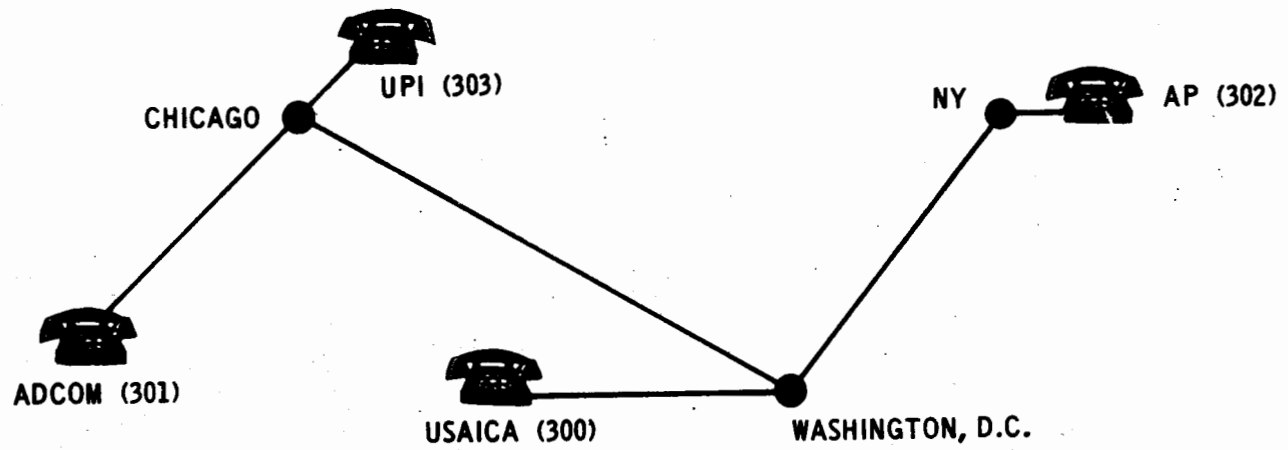

ANNEX C TO
USAICA EBS
PROCEDURES



EBS 500 NET (TELETYPEWRITER)

1. Two circuits have been provided to interconnect the 500 Net terminals--a primary circuit GT13051-001 (Appendix 1) and a backup circuit GT13051-002 (Appendix 2).
2. The primary circuit consists of several major legs, all terminating in Kansas City. If circuit trouble arises on any of these legs, it is immediately patched off at Kansas City in order that the rest of the net remain operable. Likewise, as soon as the specific location of the trouble has been determined, additional unaffected circuitry can be restored if possible. If the trouble is located in the circuitry rather than the terminal, equipment restoral is made through other paths. Since the restoration priority is only 3a, it may be expedient to use sections of the backup circuit for restoring the primary.
3. Also assigned a 3a restoration priority, the backup circuit because it is dedicated is not vulnerable to seizure for restorals in other systems. The backup would probably not be used in its entirety unless AT&T, Kansas City, were lost.



GT 13051-001 "500 NET" (PRIMARY)

1 OCT 75

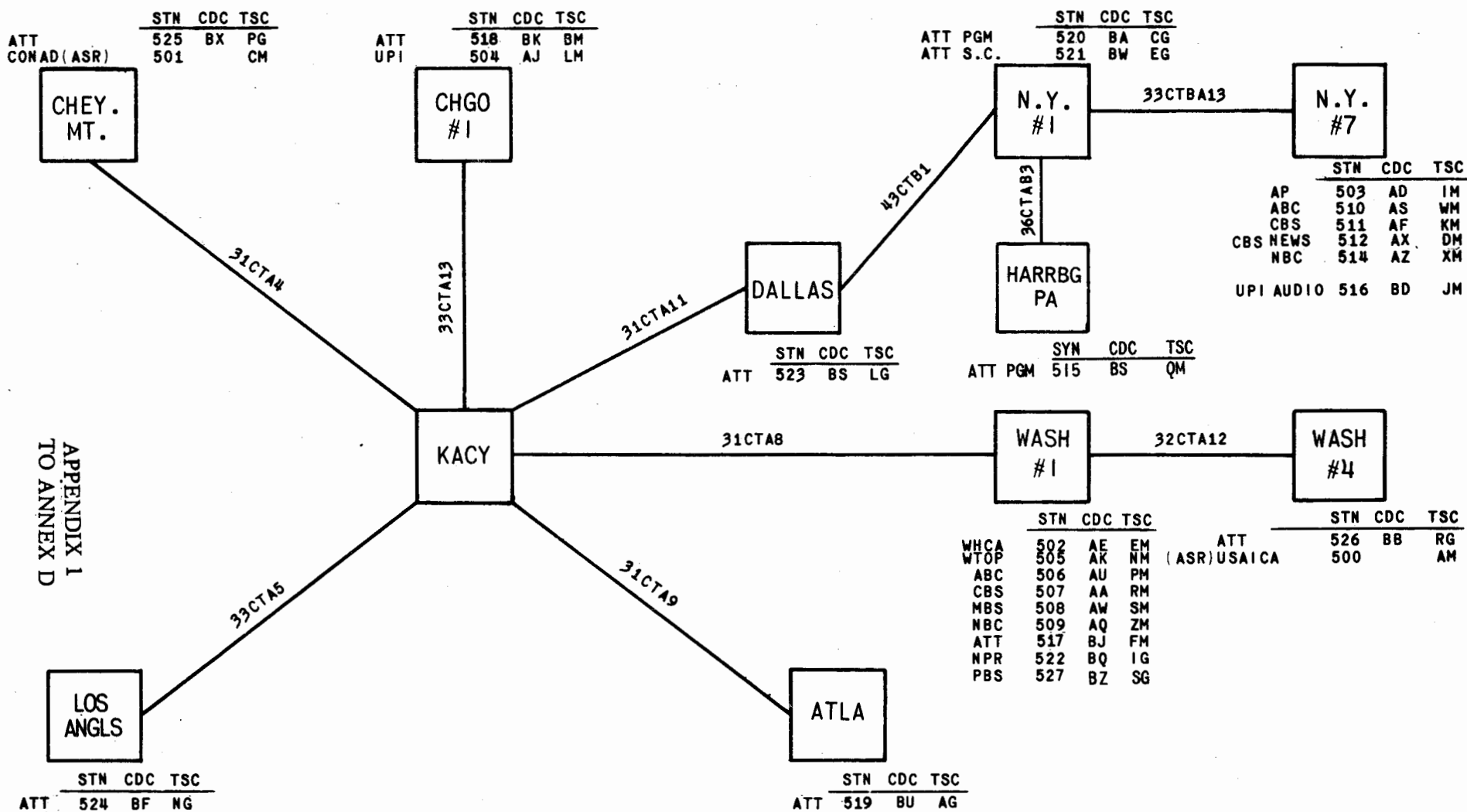

GT 13051-002 500 NET(BACKUP CIRCUITRY)

1 OCT 75

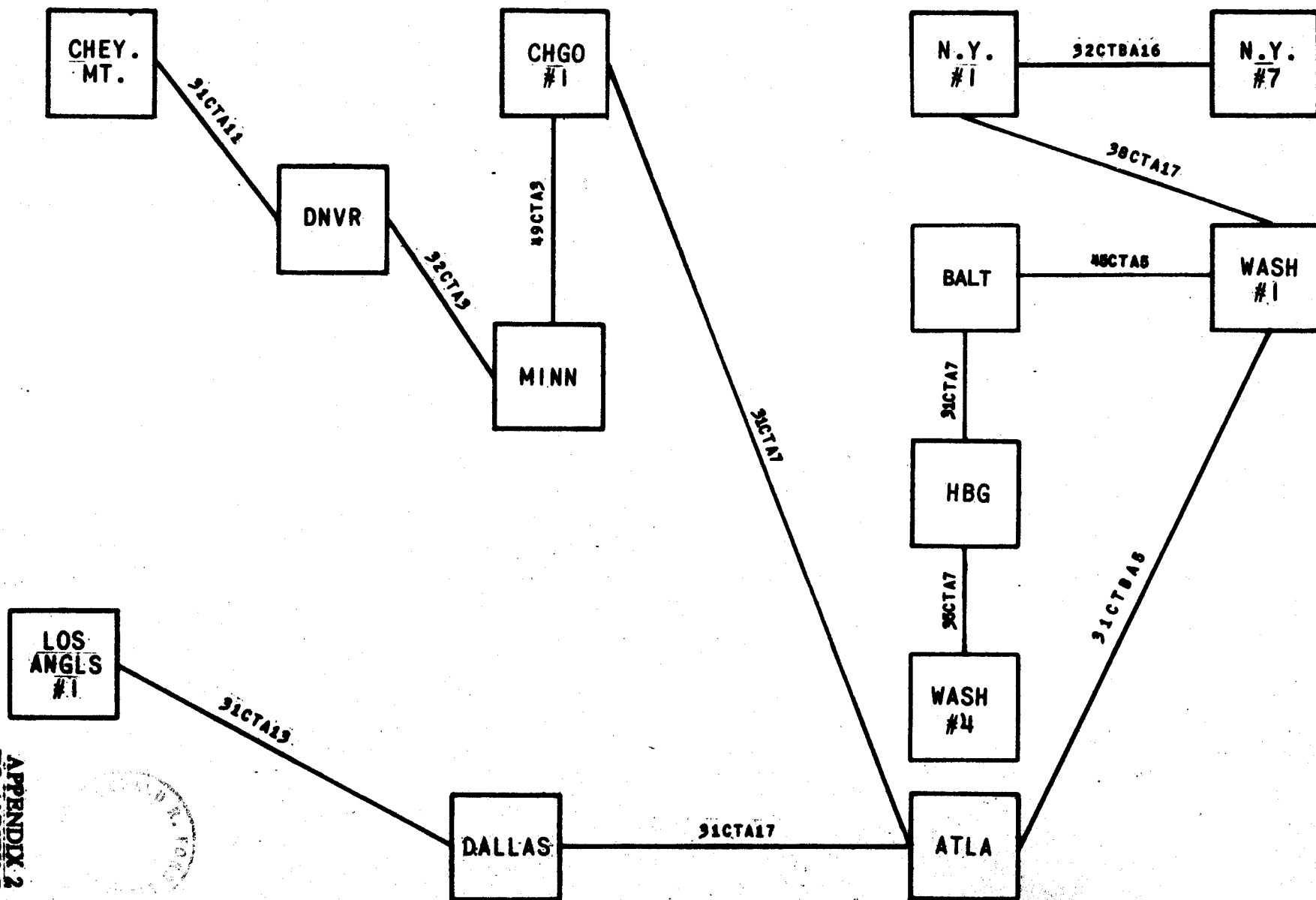

APPENDIX 2
TO ANNEX D





NIAC 1&2 CIRCUITRY

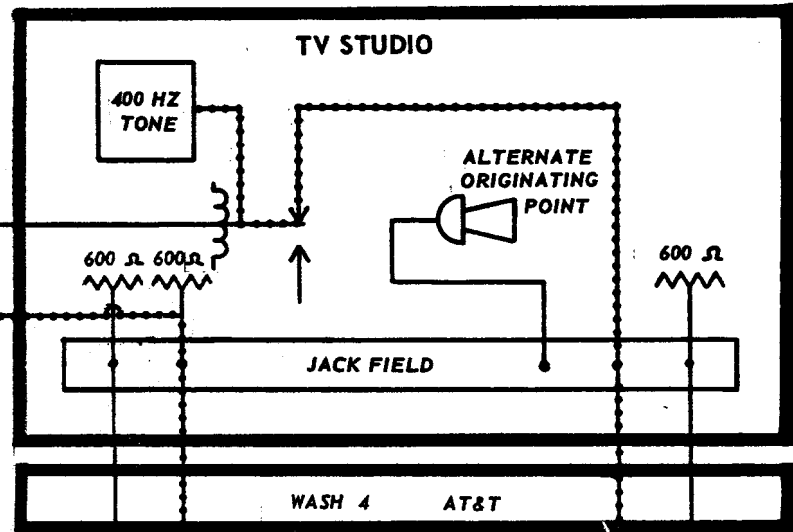
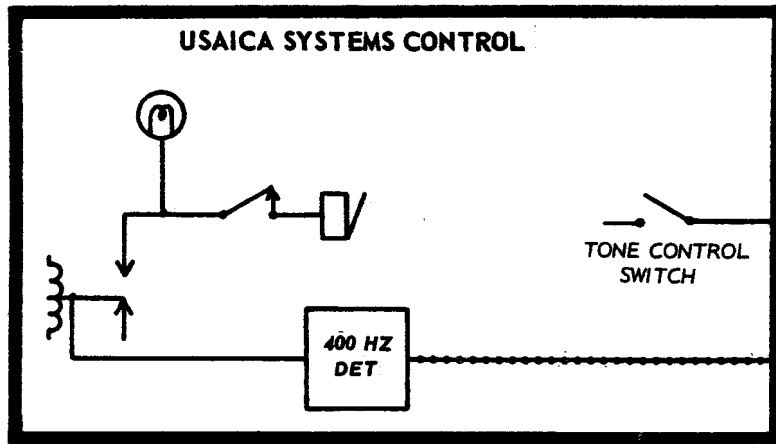

ALL PROGRAM CIRCUITS ARE 4 WIRE TELEPHONE, 300 TO 3,000 HZ VOICE GRADE QUALITY.

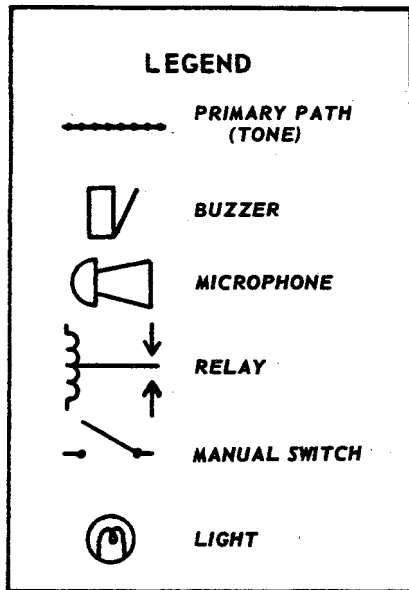

NOTE: RECONFIGURATION OF THIS CIRCUITRY IS LIKELY IN THE NEAR FUTURE.

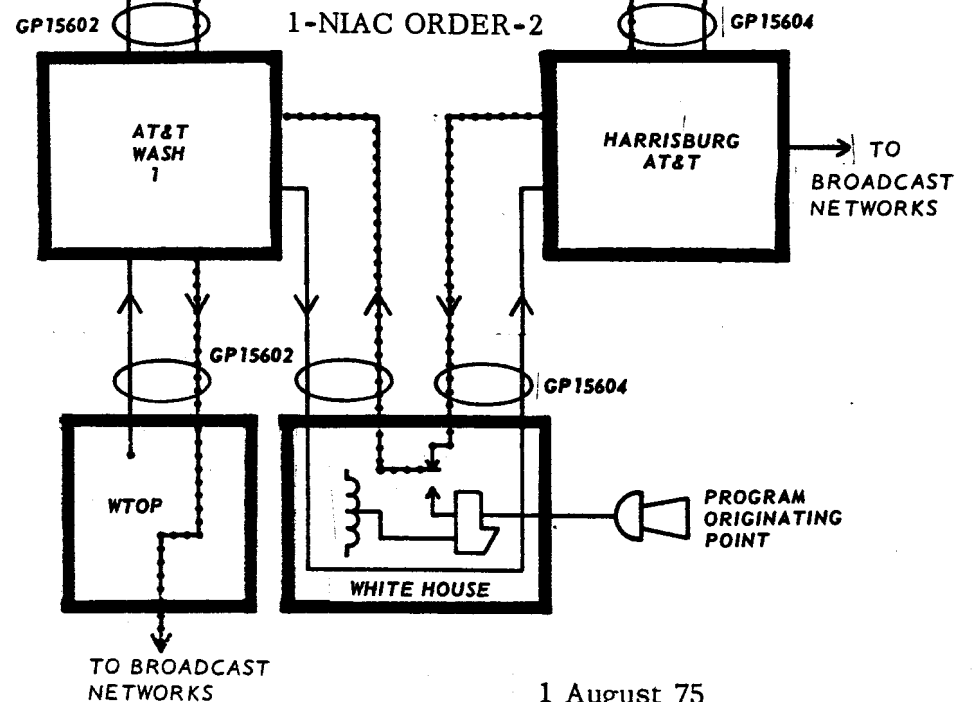

USAICA EBS Procedures Annex E to

FOR OFFICIAL USE ONLY

1 August 75

GERALD R. FORD LIBRARY

500 NET ASR TRAINING

1. General: Each COMMCEN Section operator and supervisor, as well as all COMMCEN Branch headquarters personnel, is required to maintain proficiency in operating the 500 Net ASR terminal. Proficiency will be maintained by each employee identified operating the equipment at least once per week (or tour of duty). To avoid undue disruption of service, training for an entire team should be done at one time. The team on day shift will train at the same time as COMMCEN headquarters personnel. Training will consist of loading the 500 Net Weekly Test tape in the TD, transmitting the tape into the dummy loop, polling all stations, transmitting the "Please Acknowledge" message, and operating the message addressor. A record of the training will be kept by the appropriate supervisor.

2. Sequence of Events for USAICA Training:

a. U CMC requests the U SC for authority to switch the 500 Net ASR terminal off-net.

b. U SC, via the 300 Net, coordinates with ADCOM to insure Station 501 (ADCOM) is operating properly and is able to assume activation responsibilities if necessary. WHCA will be notified that the 500 Net is off-net.

c. U SC issues authority to U CMC to switch Station 500 off-net.

d. U CMC switches 500 Net to dummy loop and notes alarm light is functioning. A passive poll is conducted to insure ASR is in fact off-net. No answer-backs should be received.

e. As training is conducted, U CMC insures that no transmissions are received on the COMMCEN EBS RO terminal. If transmissions do appear on RO printer, further training will be suspended and the U SC notified immediately.

f. At the completion of training, U CMC informs U SC Station 500 is being switched back on net. U CMC switches back on net and polls all subscribers. All stations should answer back after which U CMC notifies U SC that Station 500 is again operational.

Annex F to USAICA EBS Procedures



g. U SC notifies ADCOM and WHCA that Station 500 is again operational.

3. Sequence of Events for ADCOM Training:

a. ADCOM Systems Controller notifies U SC that ADCOM would like to patch Station 501 off-net for training.

b. U SC will concur in request unless the USAICA terminal is not operational.

c. ADCOM Systems Controller has the capability of patching his own terminal off-net.

d. U SC notifies WTO and COMMCEN that Station 501 has been taken off-net for training.

e. Upon completion of his training and restoral to normal operations, the ADCOM Systems Controller notifies U SC.

f. U SC notifies U CMC that Station 501 has been restored to normal operation.

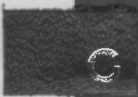

GERALD R. FORD LIBRARY

ALTERNATE METHODS OF CONTACTING USAICA/ADCOM/WHCA

USAICA

AUTOVON (use FLASH OVERRIDE)

Primary - 380-0099
1st Alternate - 380-5500
2nd Alternate - 380-5357
3rd Alternate - 380-5011 (ask operator for Systems Controller)

COMMERCIAL (use FLASH EMERGENCY)

Primary - 202/737-5721 (ask operator for 5500 or
Systems Controller)
1st Alternate - 202/484-3080 (ask operator for 380-5500 or
Systems Controller)
2nd Alternate - 703/662-9201 (ask operator for 5500 or
Systems Controller)

FEDERAL TELECOMMUNICATIONS SYSTEM

Primary - 300-380-5500/5357
Alternate - 300-380-5011 (ask operator for 5500 or
Systems Controller)

RADIO

High Frequency (HF) - USAICA continuously monitors 10.493 MHz on upper side band (voice). Contact may be made by calling WAR-42. WHCA should direct the USAICA operator as to operating frequencies and mode. When operational circuit is established, WHCA should ask for phone patch to the USAICA Systems Controller. See reference 1e (page 1) for additional detail.

Ultrahigh Frequency (UHF) - USAICA operates a UHF terminal in the 200 - 400 MHz range. The equipment, dedicated to NEACP, is operated on an on-call basis. Frequencies and procedures are issued separately in the USAICA NEACP Support Plan.

Annex G to
USAICA EBS PROCEDURES

USAICA CONTINUED

PROGRAM FEED

Primary - AUTOVON 380-0099 (use FLASH OVERRIDE).
Alternates - AUTOVON (use FLASH OVERRIDE) 380-5011.
Commercial (use FLASH EMERGENCY)
202/737-5721.
Commercial (use FLASH EMERGENCY)
703/662-9201.
FTS 300-380-5011 (ask for 5500 or
Systems Controller).
Establish HF or UHF radio contact and
ask for patch to the TV Studio

ADCOM

COMMAND DIRECTOR

AUTOVON - 834-3940 (dedicated to EBS).
Commercial - (303) 473-2585 (dedicated to EBS).

SYSTEMS CONTROLLER (use 300 Net when possible)

AUTOVON
Primary - 834-3999
Alternate - 834-1211, x3275
Commerical
Primary - (303) 473-7488
Alternate - (303) 473-4010, x3275

WHCA

DUTY OFFICER

Primary - IDS 104-4070
Alternate - AUTOVON 231-1467, x4070
2nd Alternate - Commercial (91) 395-4070

WHCA CONTINUED

COMMUNICATIONS CENTER

IDS
 Primary - 104-4010
 Alternate - 104-4147

AUTOVON
 Primary - 231-1467, x4010
 Alternate - 231-1467, x4147

Commercial
 Primary - (202) 395-4010
 Alternate - (202) 395-4147

OPERATIONS

IDS - 104-4040 (rotary)

AUTOVON - 231-1467, x4040 (rotary)

Commercial - (202) 395-4040 (rotary)

TECH CONTROL

IDS - 104-6034

AUTOVON - 231-1467, x429

Commercial - (202) 395-6034

AT&T HARRISBURG, PA

PGOC

Commercial - (717) 255-5866

Alternate - (717) 255-5850

5



REPORTS

It is essential that the results of EBS tests be disseminated formally and expeditiously in order that corrective action be taken. The formats contained herein provide for reporting the minimum essential elements of each test. It is not intended to restrict the inclusion of additional information. It is important that complete information on outages and equipment malfunctions be provided to include reasons for outages if known. Report formats are as follows:

- Closed Circuit Test - Appendix 1
- 300/500 Net Weekly Equipment Test (ICE HOUSE) - Appendix 2
- Modified Testing of the EBS - Appendix 3
- Program Feed Test (MYSTIC TARGET) - Appendix 4

NOTE: In the case of Actual EBS Activation, Termination, or NIAC Order Change, all agency elements participating are expected to keep a log of actions taken. If a report is required by DCA or other central authority, a special request will be issued on a one-time basis. The request will include the type of information required; however, it is expected that the report would closely parallel that for a Closed Circuit Test.



JOINT MESSAGEFORM

SECURITY CLASSIFICATION

UNCLAS

C
L
O
S
E
D

C
I
R
C
U
I
T

T
E
S
T

R
E
P
O
R
T

F
O
R
M
A
T

PAGE	DRAFTER OR RELEASER TIME	PRECEDENCE		LMF	CLASS	CIC	FOR MESSAGE CENTER/COMMUNICATIONS CENTER ONLY			
		ACT	INFO				DATE - TIME	MONTH	YR	
1 OF 6		ROUTINE								

BOOK

MESSAGE HANDLING INSTRUCTIONS

To be transmitted within two working days after Closed Circuit Test

FM CDRUSAICA WINCHESTER VA //CCI-TD-SC//

TO OTP WASH DC

INFO WHCA WASH DC

FCC WASH DC

CINCAD ENT AFB CO //DOCE//

DCA WASH DC //544//

UNCLAS

CITE ICA _____.

SUBJ: EBS CLOSED CIRCUIT TEST

SECTION I - ACTIVATION

1. ON (DATE), THE WTO DIRECTED THE USAICA SYSTEMS CONTROLLER TO ORIGINATE AN EBS CLOSED CIRCUIT TEST. SEQUENCE OF EVENTS FOLLOWS:

A. (TIME), WASHINGTON, DC, TIME, CALL RECEIVED FROM WTO.

B. AUTHENTICATOR CHALLENGE _____; AUTHENTICATOR RESPONSE _____.

C. TEST TIME GIVEN BY WTO WAS _____.

D. NIAC ORDER NO _____.

E. (TIME) - TEST PROGRAM SCHEDULED TO BEGIN.

6
5
4
3
2
1
0

DISTR:

USAICA MAIL DESK: PLANS OFC, COMM OPS DIV (4)

SCB: AT&T WASH 4

DRAFTER TYPED NAMED, TITLE, OFFICE SYMBOL AND PHONE

SPECIAL INSTRUCTIONS

R
E
L
E
A
S
E
R

TYPED NAME, TITLE, OFFICE SYMBOL AND PHONE

DCA AND OTP VIA TELECOPIER

SIGNATURE

Appendix 1 to Annex H

SECURITY CLASSIFICATION

UNCLAS

DD FORM 173

1 JUL 68

REPLACES DD FORM 173, 1 NOV 63 AND DD FORM 173-1, 1 NOV 63, WHICH ARE OBSOLETE.

GPO : 1969 O - 361-369

PAGE	DRAFTER OR RELEASER TIME	PRECEDENCE		LMF	CLASS	OIG	FOR MESSAGE CENTER/COMMUNICATIONS CENTER ONLY			
		ACT	INFO				DATE - TIME	MONTH	YR	
2 OF 6										

BOOK	MESSAGE HANDLING INSTRUCTIONS
-------------	--------------------------------------

F. (TIME) - TRANSMISSION OF TEST ACTIVATION MESSAGE STARTED OVER 500 NET. MESSAGE AUTHENTICATOR WAS _____.

G. (TIME) - VOICE CONFIRMATION OVER 300 NET OF RECEIPT OF TEST ACTIVATION MESSAGE BY AP, UPI, AND ADCOM.

H. (TIME) - TRANSMISSION OF TEST ACTIVATION MESSAGE OVER 500 NET COMPLETED.

I. (TIME) - THREE POLLING CYCLES COMPLETED. ACKNOWLEDGEMENT NOT RECEIVED FROM (NUMBER) STATIONS.

J. (TIME) - DELINQUENT STATIONS REACTIVATED AND TELEPHONING COMMENCED. TELEPHONE CALLS NECESSARY TO STATIONS _____.

K. (TIME) - ALL ACKNOWLEDGEMENTS COMPLETE.

L. (TIME) - NOTIFIED WTO ALL ACTIONS COMPLETED.

M. (TIME) - NOTIFIED N3WC OF EBS TEST ACTIVATION.

2. ELAPSED TIMES FROM INITIATION BY WHCA:

A. _____ MINUTES TO START OF 500 NET TRANSMISSION.

B. _____ MINUTES TO RECEIPT OF ALL 500 NET ACKNOWLEDGEMENTS.

3. PROBLEMS: [Give any problems such as complete net failure, need to transfer action to CONAD, etc., and corrective action taken.

6
5
4
3
2
1
0

DISTR:

DRAFTER TYPED NAMED, TITLE, OFFICE SYMBOL AND PHONE	SPECIAL INSTRUCTIONS
TYPED NAME, TITLE, OFFICE SYMBOL AND PHONE	
SIGNATURE	SECURITY CLASSIFICATION
RELEASER	

JOINT MESSAGEFORM						SECURITY CLASSIFICATION UNCLAS			
PAGE	DRAFTER OR RELEASER TIME	PRECEDENCE		LMP	CLASS	CIC	FOR MESSAGE CENTER/COMMUNICATIONS CENTER ONLY		
		ACT	INFO				DATE - TIME	MONTH	YR
30f 6									
BOOK	MESSAGE HANDLING INSTRUCTIONS								
<p>On 300 Net problems, state if equipment problem or customer error; if equipment problem, include corrective action taken. On 500 Net, list: (1) Any problems caused by ASR operation and corrective action taken, (2) Stations which did not acknowledge during initial three polling cycles, (3) Stations which responded to the "Please Acknowledge" message before being called, (4) Stations which did respond to "Please Acknowledge" message before being called, (5) Stations which did not respond to "Please Acknowledge" message and were telephoned, (6) State whether good copy of message was received, (7) Whether visual lamp lit, and (8) If after key operated, whether answer-back was received at ASR. If (6), (7), and (8) are affirmative, identify as subscriber error. If equipment problems existed, so state and include corrective action taken.]</p> <p>SECTION II - TERMINATION</p> <p>1. ON (DATE), THE WTO DIRECTED THE USAICA SYSTEMS CONTROLLER TO ORIGINATE AN EBS CLOSED CIRCUIT TEST TERMINATION. SEQUENCE OF EVENTS FOLLOWS:</p> <p style="padding-left: 40px;">A. (TIME), WASHINGTON, DC, TIME CALL RECEIVED FROM WTO.</p>									
DISTR:									
DRAFTER TYPED NAMED, TITLE, OFFICE SYMBOL AND PHONE						SPECIAL INSTRUCTIONS			
R E L E A S E R	TYPED NAME, TITLE, OFFICE SYMBOL AND PHONE								
	SIGNATURE								
						SECURITY CLASSIFICATION UNCLAS			

6
5
4
3
2
1
0

JOINT MESSAGEFORM

SECURITY CLASSIFICATION
UNCLAS

PAGE	DRAFTER OR RELEASER TIME	PRECEDENCE		LMP	CLASS	CIC	FOR MESSAGE CENTER/COMMUNICATIONS CENTER ONLY		
		ACT	INFO				DATE - TIME	MONTH	YR

4 OF 6

BOOK

MESSAGE HANDLING INSTRUCTIONS

B. AUTHENTICATOR CHALLENGE _____; AUTHENTICATOR RESPONSE _____.

C. TEST TERMINATION TIME WAS _____.

D. (TIME) - TRANSMISSION OF TEST TERMINATION MESSAGE STARTED OVER 500 NET. MESSAGE AUTHENTICATOR USED WAS _____.

E. (TIME) - VOICE CONFIRMATION OVER 300 NET OF RECEIPT OF TEST TERMINATION MESSAGE BY AP, UPI, AND ADCOM.

F. (TIME) - TRANSMISSION OF MESSAGE OVER 500 NET COMPLETED.

G. (TIME) - THREE POLLING CYCLES COMPLETED. ACKNOWLEDGEMENT NOT RECEIVED FROM (NUMBER) STATIONS.

H. (TIME) - DELINQUENT STATIONS REACTIVATED AND TELEPHONING COMMENCED. TELEPHONE CALLS NECESSARY TO STATIONS _____.

I. (TIME) - ALL ACKNOWLEDGEMENTS COMPLETE.

J. (TIME) - NOTIFIED WTO ALL ACTIONS COMPLETED.

K. (TIME) - NOTIFIED NBWC OF EBS CLOSED CIRCUIT TEST TERMINATION.

2. ELAPSED TIMES FROM INITIATION BY WHCA:

A. _____ MINUTES TO START OF 500 NET TRANSMISSION.

B. _____ MINUTES TO COMPLETION OF 500 NET TRANSMISSION.

6
5
4
3
2
1
0

DISTR:

DRAFTER TYPED NAMED, TITLE, OFFICE SYMBOL AND PHONE

SPECIAL INSTRUCTIONS

R
E
L
E
A
S
E
R
TYPED NAME, TITLE, OFFICE SYMBOL AND PHONE

SIGNATURE

SECURITY CLASSIFICATION
UNCLAS

JOINT MESSAGEFORM						SECURITY CLASSIFICATION UNCLAS			
PAGE	DRAFTER OR RELEASER TIME	PRECEDENCE		LMF	CLASS	GIG	FOR MESSAGE CENTER/COMMUNICATIONS CENTER ONLY		
5 OF 6		ACT	INFO				DATE - TIME	MONTH	YR
BOOK	MESSAGE HANDLING INSTRUCTIONS								
<p>C. _____ MINUTES TO RECEIPT OF ALL 500 NET ACKNOWLEDGEMENTS.</p> <p>3. PROBLEMS: [Give any problems such as complete net failure, need to transfer action to CONAD, etc., and corrective action taken. On 300 Net problems, state if equipment problem or customer error; if equipment problem, include corrective action taken. On 500 Net, list: (1) Any problems caused by ASR operation and corrective action taken, (2) Stations which did not acknowledge during initial three polling cycles, (3) Stations which responded to the "Please Acknowledge" message before being called, (4) Stations which did respond to "Please Acknowledge" message before being called, (5) Stations which did not respond to "Please Acknowledge" message and were telephoned, (6) Whether good copy of message was received, (7) Whether visual lamp lit, and (8) If after key operated, whether answer-back was received at ASR. If (6), (7), and (8) are affirmative, identify as subscriber error. If equipment problems existed, so state and include corrective action taken.]</p> <p>SECTION III - REMARKS</p> <p>Include any information, recommendations, or problems here which do</p>									
DISTR:									
DRAFTER TYPED NAMED, TITLE, OFFICE SYMBOL AND PHONE						SPECIAL INSTRUCTIONS			
R E L E A S E R	TYPED NAME, TITLE, OFFICE SYMBOL AND PHONE								
	SIGNATURE								
						SECURITY CLASSIFICATION UNCLAS			

 6
5
4
3
2
1
0

JOINT MESSAGEFORM

SECURITY CLASSIFICATION

UNCLAS

PAGE	DRAFTER OR RELEASER TIME	PRECEDENCE		LME	CLASS	CIC	FOR MESSAGE CENTER/COMMUNICATIONS CENTER ONLY		
		ACT	INFO				DATE - TIME	MONTH	YR

6 OF 6

BOOK

MESSAGE HANDLING INSTRUCTIONS

not logically fall into Sections I or II. As an example, if NIAC 1/2 circuitry is used for programming, such items as time 400 Hz tone was removed, times of talk-up, broadcast and termination of broadcasts together with circuit quality should be given. H

6
5
4
3
2
1
0

DISTR:

0

DRAFTER TYPED NAMED, TITLE, OFFICE SYMBOL AND PHONE

SPECIAL INSTRUCTIONS

R
E
L
E
A
S
E
R

TYPED NAME, TITLE, OFFICE SYMBOL AND PHONE

SIGNATURE

SECURITY CLASSIFICATION

UNCLAS

JOINT MESSAGEFORM

SECURITY CLASSIFICATION

UNCLAS

PAGE	DRAFTER OR RELEASE TIME	PRECEDENCE		LMF	CLASS	SIG	FOR MESSAGE CENTER/COMMUNICATIONS CENTER ONLY			
		ACT	INFO				DATE - TIME	MONTH	YR	
1 OF 3		ROUTINE								

BOOK

MESSAGE HANDLING INSTRUCTIONS

FM CDRUSAICA WINCHESTER VA //CCI-TD-SC//

TO OTP WASH DC

INFO WHCA WASH DC

FCC WASH DC

CINCAD ENT AFB CO //DOCE//

DCA WASH DC //544//

UNCLAS

CITE ICA _____.

SUBJ: ICE HOUSE TEST ON (DATE)

1. SEQUENCE OF SUBJECT TEST FOLLOWS:

A. (TIME), WASHINGTON, DC, TIME, CALL RECEIVED FROM WTO.

B. AUTHENTICATOR CHALLENGE _____; AUTHENTICATOR RESPONSE _____.

C. TEST TIME GIVEN BY WTO WAS _____.

D. (TIME) - TRANSMISSION OF TEST ACTIVATION MESSAGE STARTED OVER 500 NET.

E. (TIME) - VOICE CONFIRMATION OVER 300 NET OF RECEIPT OF TEST MESSAGE BY AP, UPI, AND ADCOM.

F. (TIME) - TRANSMISSION OF TEST MESSAGE OVER 500 NET COMPLETED.

DISTR:

USAICA MAIL DESK: PLANS OFC, COMM OPS DIV (4)

SCB: AT&T WASH 4

DRAFTER TYPED NAMED, TITLE, OFFICE SYMBOL AND PHONE

SPECIAL INSTRUCTIONS

TYPED NAME, TITLE, OFFICE SYMBOL AND PHONE

DCA AND OTP VIA TELECOPIER

SIGNATURE

Appendix 2 to Annex H

SECURITY CLASSIFICATION

UNCLAS

ICE HOUSE TEST REPORT FORM AT

6543210

JOINT MESSAGEFORM

SECURITY CLASSIFICATION
UNCLAS

PAGE	DRAFTER OR RELEASER TIME	PRECEDENCE		LMF	CLASS	SIG	FOR MESSAGE CENTER/COMMUNICATIONS CENTER ONLY			
		ACT	INFO				DATE - TIME	MONTH	YR	
2 OF 3										

BOOK MESSAGE HANDLING INSTRUCTIONS

G. (TIME) - THREE POLLING CYCLES COMPLETED. ACKNOWLEDGEMENT NOT RECEIVED FROM (NUMBER) STATIONS.

H. (TIME) - ALL ACKNOWLEDGEMENTS COMPLETED BY REACTIVATION OR TELEPHONING.

I. (TIME) - NOTIFIED WTO ALL ACTIONS COMPLETED.

J. (TIME) - NOTIFIED N3WC OF TEST.

2. ELAPSED TIMES FROM INITIATION BY WHCA:

A. _____ MINUTES TO START OF 500 NET TRANSMISSION.

B. _____ MINUTES TO COMPLETION OF NET TRANSMISSION.

C. _____ MINUTES TO RECEIPT OF ALL 500 NET ACKNOWLEDGEMENTS.

3. PROBLEMS: [Give any problems such as complete net failure, need to transfer action to ADCOM, etc., and corrective action taken. On 300 Net, state if equipment problem or customer error; if equipment problem, include corrective action taken. On 500 Net, list: (1) Any problems caused by ASR operation and corrective action taken, (2) Stations which did not acknowledge during initial three polling cycles, (3) Stations which responded to the "Please Acknowledge" message before being called, (4) Stations which did not respond to "Please Acknowledge" tape and were telephoned, (5) Whether good

DISTR:

DRAFTER TYPED NAMED, TITLE, OFFICE SYMBOL AND PHONE

SPECIAL INSTRUCTIONS

R
E
L
E
A
S
E
R
TYPED NAME, TITLE, OFFICE SYMBOL AND PHONE

SIGNATURE

SECURITY CLASSIFICATION
UNCLAS

JOINT MESSAGEFORM

SECURITY CLASSIFICATION
UNCLAS

PAGE	DRAFTER OR RELEASER TIME	PRECEDENCE		LMF	CLASS	CIC	FOR MESSAGE CENTER/COMMUNICATIONS CENTER ONLY			
		ACT	INFO				DATE - TIME	MONTH	YR	
3 OF 3										

BOOK

MESSAGE HANDLING INSTRUCTIONS

copy of message was received, (6) Whether visual lamp lit, and (7) If after key operated, whether answer-back was received at ASR. If (5), (6), and (7) are affirmative, identify as subscriber error. If equipment problems existed, so state and include corrective action taken.]

4. REMARKS: (Include in this paragraph such items as substantive problems which have occurred since the last test; test results of NIAC 1/2 circuitry; and any recommendations which do not logically fall in other paragraphs.) †

6
5
4
3
2
1
0

DISTR:

DRAFTER TYPED NAMED, TITLE, OFFICE SYMBOL AND PHONE

SPECIAL INSTRUCTIONS

R
E
L
E
A
S
E
R

TYPED NAME, TITLE, OFFICE SYMBOL AND PHONE

SIGNATURE

SECURITY CLASSIFICATION
UNCLAS

PAGE	DRAFTER OR RELEASER TIME	PRECEDENCE		LMF	CLASS	CIC	FOR MESSAGE CENTER/COMMUNICATIONS CENTER ONLY			
		ACT	INFO				DATE - TIME	MONTH	YR	
1 of 1		ROUTINE								

BOOK MESSAGE HANDLING INSTRUCTIONS
TO BE COMPLETED MONTHLY WITHIN THREE WORKING DAYS AFTER LAST TEST

FM CDRUSAICA WINCHESTER VA //CCI-OD-AV//
 TO DCA //CODE 544//
 CDR7TH SIG COMD //CCN-P0-0P//
 INFO AIG 870
 UNCLAS
 CITE ICA _____
 SUBJ: MODIFIED TESTING OF THE EBS, (MONTH AND YEAR)
 REF: A. DCA MSG 512-4/140, 10 JAN 67.
 B. USAICA MSG SS8845, 20 MAR 67.
 (Only list those tests which were not successful or were cancelled
 and the reasons therefore.) 4

6
5
4
3
2
1
0

M
O
D
I
F
I
E
D

T
E
S
T

R
E
P
O
R
T

F
O
R
M
A
T

DISTR:
USAICA MAIL DESK: COD {2}, LOG DIV, PLANS OFC, AND SCB

<table border="1" style="width:100%; border-collapse: collapse;"> <tr> <td colspan="2" style="padding: 2px;">DRAFTER TYPED NAMED, TITLE, OFFICE SYMBOL AND PHONE</td> </tr> <tr> <td style="width:10%; padding: 2px; text-align: center;">R E L E A S E R</td> <td style="padding: 2px;">TYPED NAME, TITLE, OFFICE SYMBOL AND PHONE</td> </tr> <tr> <td style="padding: 2px;"></td> <td style="padding: 2px;">SIGNATURE</td> </tr> </table>	DRAFTER TYPED NAMED, TITLE, OFFICE SYMBOL AND PHONE		R E L E A S E R	TYPED NAME, TITLE, OFFICE SYMBOL AND PHONE		SIGNATURE	<table border="1" style="width:100%; border-collapse: collapse;"> <tr> <td colspan="2" style="padding: 2px;">SPECIAL INSTRUCTIONS</td> </tr> <tr> <td colspan="2" style="padding: 2px; text-align: center;">DCA VIA TELECOPIER</td> </tr> <tr> <td colspan="2" style="padding: 2px; text-align: right;">Appendix 3 to Annex H</td> </tr> <tr> <td colspan="2" style="padding: 2px;">SECURITY CLASSIFICATION</td> </tr> <tr> <td colspan="2" style="padding: 2px; text-align: center;">UNCLAS</td> </tr> </table>	SPECIAL INSTRUCTIONS		DCA VIA TELECOPIER		Appendix 3 to Annex H		SECURITY CLASSIFICATION		UNCLAS	
DRAFTER TYPED NAMED, TITLE, OFFICE SYMBOL AND PHONE																	
R E L E A S E R	TYPED NAME, TITLE, OFFICE SYMBOL AND PHONE																
	SIGNATURE																
SPECIAL INSTRUCTIONS																	
DCA VIA TELECOPIER																	
Appendix 3 to Annex H																	
SECURITY CLASSIFICATION																	
UNCLAS																	

PAGE	DRAFTER OR RELEASER TIME	PREFERENCE		LME	CLASS	CIC	FOR MESSAGE CENTER/COMMUNICATIONS CENTER ONLY		
		ACT	INFO				DATE - TIME	MONTH	YR

1 OF 2 ROUTINE
 MESSAGE HANDLING INSTRUCTIONS
 To be completed within three working days after test.

FM CDRUSAICA WINCHESTER VA //CCI-OD-AV//
 TO OTP WASH DC
 INFO WHCA WASH DC
 DCA WASH DC //544//
 UNCLAS
 CITE ICA _____

SUBJ: EBS MYSTIC TARGET TEST

1. ON (DATE) THE WTO DIRECTED THE USAICA SYSTEMS CONTROLLER TO ORIGINATE AN EBS MYSTIC TARGET TEST. THE SEQUENCE OF EVENTS FOLLOWS:

- A. (TIME), WASHINGTON, DC, TIME, CALL RECEIVED FROM (NAME), WTO, OVER (TELEPHONE NUMBER OR RADIO FREQUENCY).
- B. AUTHENTICATOR CHALLENGE _____; AUTHENTICATOR RESPONSE _____
- C. NIAC ORDER NO. _____ SIMULATED.
- D. (TIME) U SC SIMULATED RELEASE OF THE EMERGENCY ACTION NOTIFICATION MESSAGE.
- E. (TIME) U SC ISSUED PROGRAM FEED ORDER TO U EMB.
- F. (TIME) WTO CIRCUITRY EXTENDED TO U EMB AT TV STUDIO. (Use on HF radio tests only.)

DISTR:
 USAICA MAIL DESK: PLANS OFC, SCB, COMM OPS DIV {3}, LOG DIV
 AVB: WASH-4

RELEASER	DRAFTER TYPED NAMED, TITLE, OFFICE SYMBOL AND PHONE	SPECIAL INSTRUCTIONS DCA AND OTP VIA TELECOPIER
	TYPED NAME, TITLE, OFFICE SYMBOL AND PHONE	
	SIGNATURE	Appendix 4 to Annex H
SECURITY CLASSIFICATION UNCLAS		

6543210

MYSTIC TARGET TEST REPORT FORMAT

JOINT MESSAGEFORM

SECURITY CLASSIFICATION
UNCLAS

PAGE	DRAFTER OR RELEASER TIME	PRECEDENCE		LMF	CLASS	SIG	FOR MESSAGE CENTER/COMMUNICATIONS CENTER ONLY			
		ACT	INFO				DATE - TIME	MONTH	YR	
2 OF 2										

BOOK

MESSAGE HANDLING INSTRUCTIONS

G. (TIME) U EMB INFORMED (WTO/U SC) THAT EBS PROGRAM EQUIPMENT WAS ACTIVATED FOR AN EBS MYSTIC TARGET TEST.

H. PROGRAM WAS RECEIVED BY USAICA OVER (TELEPHONE NUMBER OR RADIO FREQUENCY); TALK-UP TAPE PLAYED AT (TIME); PROGRAM COMPLETED AT (TIME).

I. (TIME) WTO TERMINATED EBS MYSTIC TARGET TEST.

2. ELAPSED TEST ACTIVATION TIME FROM INITIATION BY WHCA:

A. _____ MINUTES TO ACTIVATION OF EBS CIRCUITRY BY PGO.

B. _____ MINUTES TO DEACTIVATION OF EBS CIRCUITRY BY PGO.

C. _____ MINUTES TO CONCLUSION OF EBS MYSTIC TARGET TEST.

3. REMARKS: (Include problems encountered, recommendations for corrective action, quality of program transmission, etc.)

6
5
4
3
2
1
0

DISTR:

DRAFTER TYPED NAMED, TITLE, OFFICE SYMBOL AND PHONE

SPECIAL INSTRUCTIONS

R
E
L
E
A
S
E
R

TYPED NAME, TITLE, OFFICE SYMBOL AND PHONE

SIGNATURE

SECURITY CLASSIFICATION
UNCLAS

6221

GERALD R. FORD LIBRARY

EBS 300/500 NET
ADMINISTRATIVE CONTACTS
MAILING ADDRESSES AND TELEPHONE NUMBERS

Station

500 Cdr, USAICA
300 ATTN: CCI-OD
P.O. Box 886
Winchester, VA 22601

Contact: Mr. Richmond
AUTOVON 380-5353
(202) 737-5721, x5353

501 HQ ADCOM
301 ATTN: DOCEE
Ent AFB
Colorado Springs, CO 80912

Contact: LTC Roland L. Hintgen
AUTOVON 834-3999
(303) 473-4010, x3264

502 White House Comm. Agency
The White House
ATTN: Comm Br Sta 502
Washington, DC 20500

Contact: CTCS W. H. Stoner, Jr.
(202) 395-4010
AUTOVON 231-1467, x4010

503 Associated Press
302 4th Flr Comm Dept
50 Rockefeller Plaza
New York, NY 10020

Contact: Mr. Edward L.
Fornell, Sr.
(212) 262-8128

504 United Press International
303 5th Floor
430 N. Michigan St.
Chicago, IL 60611

Contact: Mr. Bill Ferguson
(312) 467-5050

Station

505 WTOP Radio & Broadcast House
Radio Master Control Room
40th & Brandywine Sts, N.W.
Washington, DC 20016

Contact: Mr. N. Richardson
(202) 686-6055

506 American Broadcasting Co.
Radio News Room
1124 Connecticut Ave., N.W.
Washington, DC 20036

Contact: Mr. K. J. Scott
(202) 393-7700, x288

507 Columbia Broadcasting System,
Inc.
Radiotape Room - 2nd Floor
2020 M St., N.W.
Washington, DC 20036

Contact: Mr. J. Clucas
(202) 296-1234, x203

508 Mutual Broadcasting System
Lower Level World Center Bldg
918 16th St., N.W.
Washington, DC 20006

Contact: Mr. Terrence Skelton
(202) 785-6412

509 National Broadcasting Co., Inc.
Transmission Center
4001 Nebraska Ave., N.W.
Washington, DC 20016

Contact: Mr. Al Aebig
(202) 362-3077

Annex I to USAICA EBS PROCEDURES

Station

510 American Broadcasting Co. News
ATTN: (Contact)
(1926/5)
7 West 66th St.
New York, NY 10023

Contacts: Mr. J. F. Keating
(212) 581-7777, x7065
 Mr. T. O'Brien
(212) 581-7777, x7501

511 CBS
Room 1402
524 W. 57th St.
New York, NY 10019

Contact: Ms. Marie
 Betzig
(212) 765-4321, x2041

512 Columbia Broadcasting System
(News)
Room 1E40
524 W. 57th St.
New York, NY 10019

Contact: Mr. Lee Otis
(212) 765-4321, x3658

513 Unassigned

514 National Broadcasting Co.,
Inc.
Room 1240W
30 Rockefeller Plaza
New York, NY 10020

Contact: Mr. Martin Meaney
(212) 247-8300, x3354

Station

515 AT&T Company
Operations Manager
210 Pine St. - 5th Flr
Harrisburg, PA 17101

Contact: Mr. W. P. Over
(717) 255-5850

516 United Press International
(Audio)
Room 1218
220 E. 42nd St.
New York, NY 10017

Contact: Mr. Bill Wilson
(212) 867-3994

517 American Tel & Tel Co.
Rm 403 TV Operating Center
725 13th St., N.W.
Washington, DC 20005

Contact: Mr. R. E. Wright
(202) 466-5481

518 American Tel & Tel Co.
Rm 1002, TV Operating Center
85 W. Congress Pkwy
Chicago, IL 60605

Contact: Mr. Ron Matz
(312) 368-3123

519 American Tel & Tel Co.
TV Operating Center
51 Ivy St., N.E., Room 309
Atlanta, GA 30303

Contact: Mr. A. B. Johnson
(404) 529-8083

Station

520 American Tel & Tel Co.
Rm 2471, N.R. General
Control
32 Avenue of the Americas
New York, NY 10013

Contact: Mr. Dan Rousseau
(212) 393-7262
Mr. R. H. Oleksik
(212) 393-5324

521 American Tel & Tel Co.
Rm 2432, Network Operations Center
32 Avenue of the Americas
New York, NY 10013

Contact: Mr. M. Stamm
(212) 393-5498

522 National Public Radio
2025 M. Street, N.W.
Washington, DC 20036

Contacts: Mr. George Geesey
Mr. Dick Cassidy
(202) 785-5445

523 American Tel & Tel Co.
Rm 916, TV Operating Center
4100 Bryan St.
Dallas, Texas 75204

Contact: Mr. H. W. Sloan
(214) 745-2566

524 Pacific Tel & Tel Co.
Rm 1202, LA-AOC
434 S. Grand Ave.
Los Angeles, CA 90017

Contact: Mr. Richard Peters
(213) 621-6376

Station

525 American Tel & Tel Co.
Rm 3101 NCMC
Ent AFB
Colorado Springs, CO 80912

Contact: Mr. J. T. Elliott
AUTOVON 834-1211, x3316
(303) 636-4708

526 American Tel & Tel Co.
Washington #4 Ofc
11820 Leesburg Pike Rm 106
Herndon, VA 22070

Contact: Operations Manager
(202) 466-3360

527 Public Broadcast Service
475 L'Enfant Plaza W., S.W.
Washington, DC 20024

Contact: Mr. Dan Wells
(202) 488-5110



EMERGENCY BROADCAST SYSTEM
500 NET TELEPHONE NUMBERS

FOR OPERATIONAL USE

STATION		TELEPHONE NUMBERS	
NO.	LOCATION	PRIMARY	ALTERNATE
500	USAICA	AUTOVON 380-5266 (202) 737-5721 x5264	AUTOVON 246-5266 (703) 662-9201 x5264
501	ADCOM, Colo	AUTOVON 834-3999 (303) 473-7488	AUTOVON 834-1211 x3275 (303) 743-4010 x3275
502	WHCA, Wash	AUTOVON 231-1467 x4010 (202) 395-4010	AUTOVON 231-1467 x4147 (202) 395-4147
503	AP, NY	(212) 262-8128	(212) 262-8126
504	UPI, Chicago	(312) 467-5066	(312) 467-5055 x32
*505	WTOP, Wash	(202) 686-6125	(202) 686-6100
**506	ABC, Wash	(202) 393-7700 x264	
***507	CBS, Wash	(202) 296-8750	
+508	MBS, Wash	(202) 785-6400	
509	NBC, Wash	(202) 362-3077	(202) 686-4395
510	ABC, NY	(212) 581-7777 x7515 ask for Charge Editor	(212) 787-5076
++511	CBS, NY	(212) 582-3830	(212) 765-4321 x2031
512	CBS-News, NY	(212) 586-7828	(212) 765-4321 x3615

- * - closed 0001-0600 Sunday; 0100-0530 all other days
- ** - closed 2200-0600 Mon thru Fri, closed Sat and Sun 2200-0800
- *** - closed Mon thru Fri 2130-0600; closed Sat and Sun 2230-0700
- + - closed 2400-0500 weekdays; 2400-0600 Sat and Sun
- ++ - closed 2300-0900 daily

Annex J to USAICA EBS PROCEDURES



STATION		TELEPHONE NUMBERS	
NO.	LOCATION	PRIMARY	ALTERNATE
513	unassigned		
514	NBC, NY	(212) 582-9362	(212) 247-8300 x2468
515	Harrisburg, PA, PGO	(717) 255-5866	
516	UPI-Audio, NY	(212) 867-3995 (rotary)	
517	AT&T TVOC, Wash	(202) 628-9057	(202) 393-8377
518	AT&T TVOC, Chicago	(312) 368-3123	(312) 368-3120
519	AT&T TVOC, Atlanta	(404) 529-8083	(404) 529-7492
520	AT&T NR Gen Con, NY	(212) 226-3130	(212) 393-6171
521	AT&T STATC, NY	(212) 393-6771 (rotary)	
*522	Nat Pub Radio Ntwk	(202) 785-5545	(202) 785-5380
523	AT&T TVOC, Dallas	(214) 745-4501	(214) 821-0507
524	PT&T LA-AOC, L.A.	(213) 621-6468 (rotary)	(213) 621-6378
525	AT&T, NCMC	AUTOVON 834-1211 x3317	
**526	AT&T, WASH 4	(202) 466-3360	(202) 737-5721 x5741
***527	Pub Broadcast Svc	(202) 488-5147	

* - open 0900-2300 Mon thru Fri

** - open 0800-1630 Mon thru Fri

*** - closed 0300-0600

LA-AOC - Los Angeles Audio Operating Center

NR - Network Radio

NCMC - NORAD Cheyenne Mountain Complex

PGOC - Program Operations Center

STATC - Status Center

TVOC - Television Operating Center

K

GERALD R. FORD LIBRARY

EBS CONTACTS
(GOVERNMENT PROCEDURES)

Organization: Office of Telecommunications Policy, Executive
Office of the President

Contact: LTC Harry W. Ingold, USAF

Telephone: IDS 103-3973
Commercial (202) 395-3973

Address: Office of Telecommunications Policy
Executive Office of the President
Washington, DC 20504

Organization: White House Communications Agency

Contact: MAJ Edward E. Nelson/MAJ Tom Graybill

Telephone: IDS 104-4040
Commercial (202) 395-4040
AUTOVON 231-1467, x4040

Address: Commander, WHCA
The White House
Washington, DC 20500

Organization: Federal Communications Commission

Contact: Emmett B. Kitchen

Telephone: IDS 101-27007
Commercial (202) 632-7007

Address: Engineering Assistant to
Commissioner Charlotte T. Reid
Federal Communications Commission
1919 M Street, NW
Washington, DC 20554

Annex K to USAICA EBS Procedures

Organization: Federal Communications Commission

Contact: Raymond W. Seddon

Telephone: 632-7232
IDS 101-27232

Address: Chief, Emergency Communications Division
Federal Communications Commission
1919 M Street, NW
Washington, DC 20554

Organization: Federal Communications Commission (Mailing of
FCC Publications)

Contact: Donald Aines

Telephone: IDS 101-27232
Commercial (202) 632-7232

Address: Emergency Communications Division
Federal Communications Commission
1919 M Street, NW
Washington, DC 20554

Organization: National Security Agency

Contact: Mrs. Doris Pollock

Telephone: Commercial (202) 688-8114
AUTOVON 235-8114

Address: Director, National Security Agency
ATTN: S14
Ft Meade, MD 20755

Organization: American Telephone & Telegraph Company

Contact for Government Communications: Mr. Robert L. Wright

Telephone: CML (202) 466-4093

Address: American Telephone & Telegraph Company
2055 L Street, NW
Washington, DC 20036

Contact for Harrisburg PGO (NIAC Order 2): Mr. W. P. Over

Telephone: CML (717) 255-5850

Address: AT&T Company
Mr. W. P. Ober
Operations Manager
210 Pine Street - 2nd Floor
Harrisburg, PA 17101

Organization: Aerospace Defense Command

Contact: LTC Roland L. Hintgen/MAJ Carlos Harlow

Telephone: AUTOVON 834-3999/1211, x3275
CML (303) 473-7488

Address: HQ, ADCOM
ATTN: DOCE
Ent AFB
Colorado Springs, CO 80912

Organization: Defense Communications Agency

Contact: Mr. Robert E. Lee

Telephone: IDS 11-21610
AUTOVON 385-1114
Commercial (202) 692-1610

Address: Chief, Washington Complex Division
Defense Communications Agency
Washington, DC 20504

Organization: U. S. Army Interagency Communications Agency

Contacts: Mr. F. James Richmond
Mr. William A. Salyan

Telephone: IDS 163-5353
AUTOVON 380-5353
Commercial (202) 757-5721, x5353

Address: Commander
U. S. Army Interagency Communications Agency
ATTN: CCI-OD
P. O. Box 886
Winchester, VA 22601

FOR OFFICIAL USE ONLY